

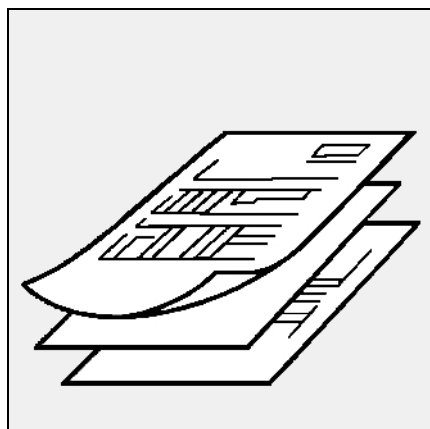

C120, C160, C210 GX507/8



Données techniques
Brûleurs gaz..... 2-10

FR

Dati tecnici
Bruciatori di gas 2-10

IT

Datos técnicos
Quemadores de gas 2-10

ES

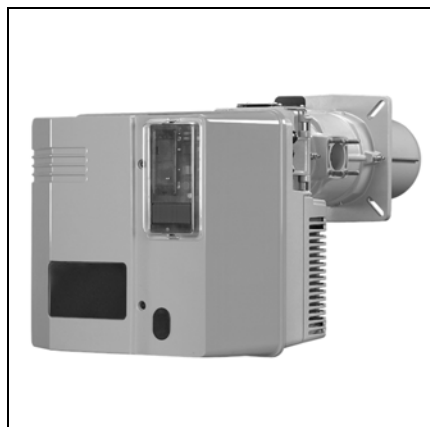

Technical data
Gas burners 2-10

EN

Technische Daten
Gasgebläsebrenner..... 2-10

DE



Технические характеристики
на газовые горелки 2-10

RU



Pièces de rechange
Pezzi di ricambio
Piezas de recambio
Spare parts list
Ersatzteilliste
Список запчастей 11-23

RU

Schémas électrique et hydraulique
Schemi elettrico e idraulico
Esquema eléctrico y hidráulico
Electric and hydraulic diagrams
Elektro- und Hydraulikschema
Электрические и гидравлические схемы 25-31

RU

Principaux composants / Caractéristiques d'utilisation

Componenti principali / Caratteristiche d'impiego

Componentes principales / Características de utilización

Main components / Characteristics of use

Wichtigste Komponenten / Betriebsdaten

Основные компоненты / Рабочие характеристики

Principaux composants

- Coffret de commande et sécurité:
SG 513
- Détecteur de flamme:
Sonde d'ionisation
- Moteur de ventilation:
230/400V, 50Hz, 2900 tr/min
C 120,160 2,2kW
C 210 2,7kW
- Contacteur moteur:
400V LC 1K
- Relais thermique:
400V LR 2K 5,5/8,0A
- Turbine du ventilateur:
C120,160 Ø240 x 114 Ø24
C210 Ø250 x 114 Ø24
- Transformateur d'allumage:
2 x 7,5kV
- Commande du volet d'air:
servomoteur SQN 31 481/30s
- Pressostat d'air:
LGW 3 A2

Componenti principali

- Programmatore di comando:
SG 513.
- Rilevatore di fiamma:
Sonda di ionizzazione
- Motore del ventilatore:
230/400 V, 50Hz, 2900min⁻¹
C 120,160 2,2kW
C 210 2,7kW
- Contattore motore:
400V LC 1K
- Relè termico:
400V LR 2K 5,5/8,0A
- Turbina del ventilatore:
C120,160 Ø240 x 114 Ø24
C210 Ø250 x 114 Ø24
- Trasformatore d'accensione:
2 x 7,5kV
- Comando della serranda aria:
Servomotore SQN 31 481/30s
- Pressostato aria:
LGW 3 A2

Principales componentes

- Cajetín de control y seguridad:
SG 513
- Detector de llama:
Sonda de ionización
- Motor de ventilación:
230/400V, 50Hz, 2900min⁻¹
C 120,160 2,2kW
C 210 2,7kW
- Contactor motor:
400V LC 1K
- Relé térmico:
400V LR 2K 5,5/8,0A
- Turbina del ventilador:
C120,160 Ø240 x 114 Ø24
C210 Ø250 x 114 Ø24
- Transformador de encendido:
2 x 7,5kV
- Control trampilla de aire:
Servomotor SQN 31 481/30s
- Presostato de aire:
LGW 3 A2

Caractéristiques d'utilisation

- Température ambiante:
- d'utilisation: - 5... 40°C
- de stockage: - 20... 70°C
- Tension / Fréquence:
- circuit commande
230 VAC -15...+10% - 50Hz^{±1%}
monophasé
- circuit puissance
400 VAC -15...+10% - 50 Hz^{±1%}
triphase
- Degré de protection:
- IP 41

 Dans le cas d'une alimentation électrique sans neutre à la terre, installer un transformateur d'isolement de 2,5 A/630 VA.

Caratteristiche d'impiego

- Temperatura ambiente:
- d'utilizzazione: - 5... 40°C
- di stoccaggio: - 20... 70°C
- Tensione / Frequenza:
- circuito comando
230VAC -15...+10% - 50Hz^{±1%}
monofase
- circuito potenza
400 VAC -15...+10% - 50Hz^{±1%}
trifase
- Grado di protezione:
- IP 41

 In caso di alimentazione elettrica senza neutro collegato a terra, installare un trasformatore d'isolamento di 2,5 A/630 VA.

Características de utilización

- Temperatura ambiente:
- de utilización: - 5... 40°C
- de almacenamiento: - 20... 70°C
- Tensión eléctrica / Frecuencia:
- circuito control
230 VAC -15...+10% - 50 H^{±1%}
monofásico
- circuito potencia
400 VAC -15...+10% - 50 Hz^{±1%}
trifásico
- Grado de protección:
- IP 41

 En caso de alimentación eléctrica sin neutro a tierra instalar un transformador de aislamiento de 2,5 A/630 VA.

Principaux composants / Caractéristiques d'utilisation
Componenti principali / Caratteristiche d'impiego
Componentes principales / Características de utilización
Main components / Characteristics of use
Wichtigste Komponenten / Betriebsdaten
Основные компоненты / Рабочие характеристики

Main components

- Control unit:
SG 513
- Flame detector:
Ionization probe
- Fan motor:
230/400V, 50Hz, 2900 min⁻¹
C 120,160 2,2kW
C 210 2,7kW
- Motor contactor:
400V LC 1K
- Thermal relay:
400V LR 2K 5,5/8,0A
- Fan turbine:
C120,160 Ø240 x 114 Ø24
C210 Ø250 x 114 Ø24
- Ignition transformer:
2 x 7,5kV
- Air flap control:
Servomotor SQN 31 481/30s
- Air pressure switch:
LGW 3 A2

Wichtigste Komponenten

- Feuerungsautomat :
SG 513
- Flammenüberwachung :
Ionisationssonde
- Gebläsemotor :
230/400V, 50Hz 2900min⁻¹
C 120,160 2,2kW
C 210 2,7kW
- Motorschütz :
400V LC 1K
- Überstromrelais Gebläsemotor :
400V LR 2K 5,5/8,0A
- Lüfterrad :
C120,160 Ø240 x 114 Ø24
C210 Ø250 x 114 Ø24
- Zündtrafo :
2 x 7,5kV
- Luftklappensteuerung :
Stellantrieb SQN 31 481/30s
- Luftdruckwächter :
LGW 3 A2

Основные компоненты

- Прибор управления:
SG 513
- Контроль факела:
ионизационный зонд
- Двигатель воздуходувки:
230/400 В, 50 Гц, 2900 мин⁻¹
C120,160 2,2кВт
C210 2,7кВт
- Контактор двигателя:
400В LC 1К
- Термореле:
400В LR 2К 5,5/8,0А
- Колесо вентилятора:
C120,160 Ø240 x 114 Ø24
C210 Ø250 x 114 Ø24
- Трансформатор розжига
2 x 7,5кВ
- Управление воздушной заслонкой:
серводвигатель SQN 31 481/30сек.
- Реле давления воздуха:
LGW 3 A2

Characteristics of use

- Ambient temperature :
- for use : - 5... 40°C
 - for storage : - 20... 70°C
- Voltage / Frequency:
- control circuit
230VAC -15...+10% - 50Hz^{±1%}
single-phase
 - power circuit
400VAC -15...+10% - 50Hz^{±1%}
triphasé
- Protection level :
- IP 41

Betriebsdaten

- Umgebungstemperatur:
- Betriebstemperatur:- - 5... 40°C
 - Lagerungstemperatur: - 20... 70°C
- Spannung/Frequenz:
- Steuerkreis
230 VAC -15...+10% - 50Hz^{±1%}
einphasig
 - Leistungskreis
400 VAC -15...+10% - 50Hz^{±1%}
dreiphasig
- Schutzart:
- IP 41

Рабочие характеристики

- Температура окружающей среды:
- Рабочая температура: -5...40°C
 - Температура хранения: -20...70°C
- Напряжение / частота:
- Цепь управления
230 В переменный ток -15...+10%
-50 Гц^{±1%} однофазный
 - Силовая цепь
400 В переменный ток -15...+10%
-50 Гц^{±1%} трехфазный
- Вид защиты:
- IP 41

 With an electrical power supply without an earthed neutral, install a 2,5 A/630 VA isolation transformer

 Bei einer Stromversorgung ohne geerdeten Nullleiter einen Isoliertrafo mit 2,5 A/630 VA installieren.

 При электропитании без заземленной нейтрали смонтируйте изоляционный трансформатор с 2,5 А / 630 ВА.

Courbes de puissance
Curve di potenza
Diagramas de potencia
Power graphs
Arbeitsfelder
Рабочие поля

C120
 G20 P20 MBVEF 420FP
 P20 VGD DN50
 P20 VGD DN65

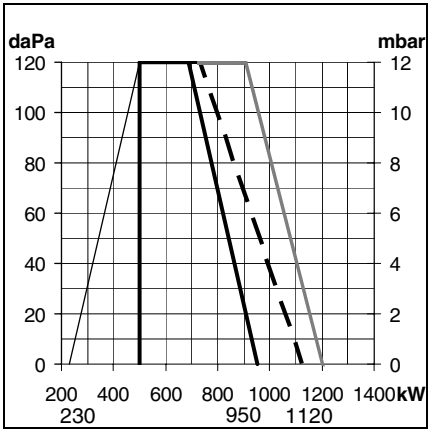

C160
 G20 P20 VGD DN65
 P20 VGD DN80

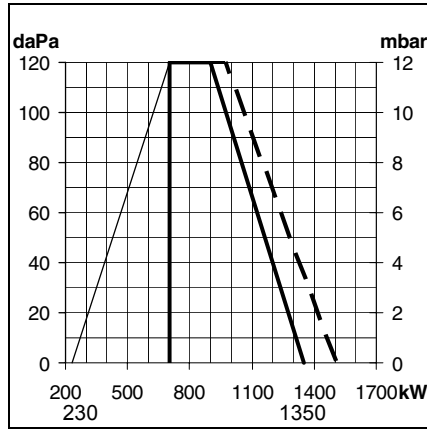

C210
 G20 P20 VGD DN65
 P20 VGD DN80

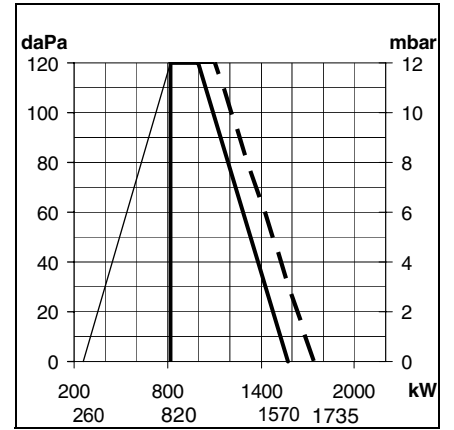

G20 P25 MBVEF 420FP
 P25 VGD DN50
 P25 VGD DN65

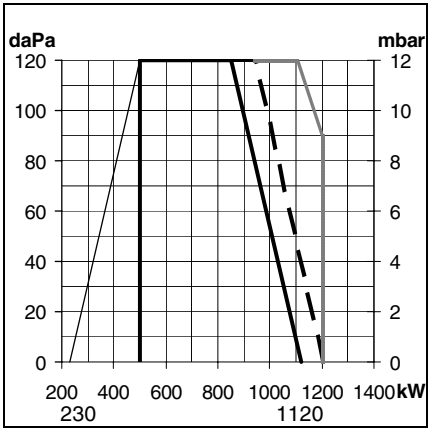

G20 P25 VGD DN65
 P25 VGD DN80

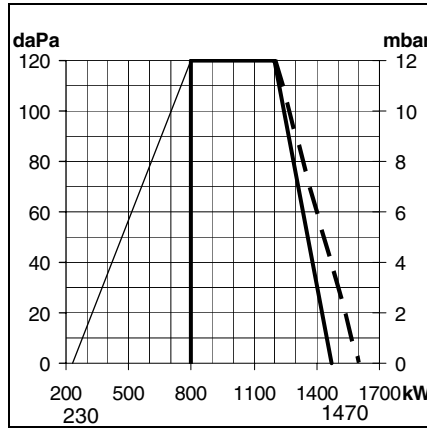

G20 P25 VGD DN65
 P25 VGD DN80

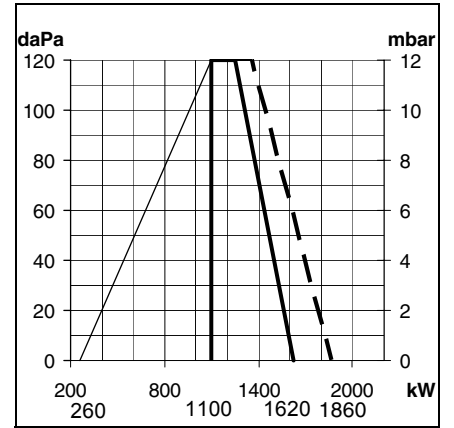

G20 P40/50 MBVEF 420FP
 P100/150/300 MBVEF 412

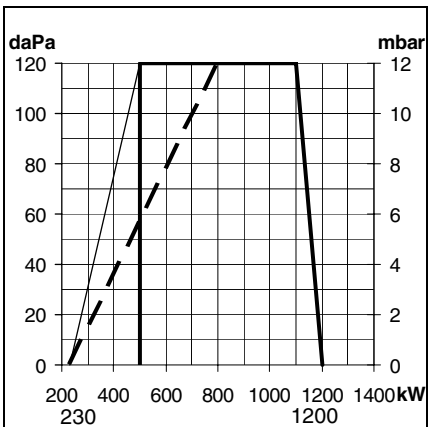

G20 P40 MBVEF 420FP
 P40 VGD DN65
 P100/150 MBVEF 420FP
 P300 MBVEF 412

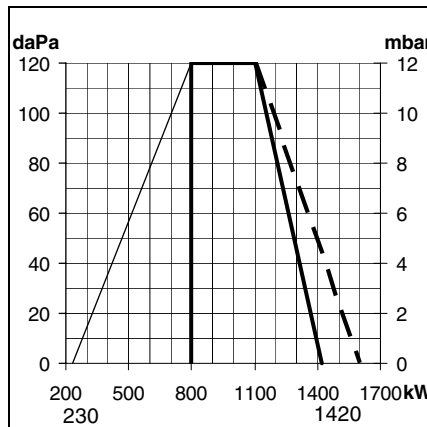

G20 P40 VGD DN50
 P40 VGD DN65
 P50 MBVEF 425
 P100/150 MBVEF 420
 P300 MBVEF 412

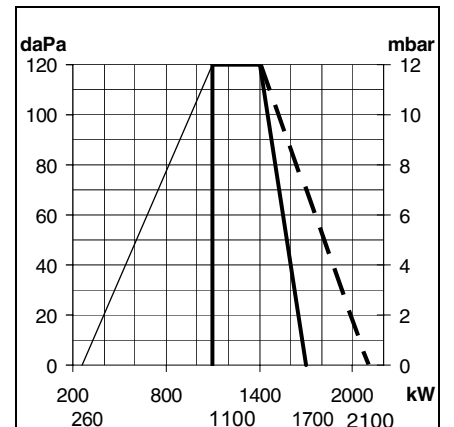

Courbes de puissance
Curve di potenza
Diagramas de potencia
Power graphs
Arbeitsfelder
Рабочие поля

C120
 G25 P25 MBVEF 420FP
 P300 MBVEF 412

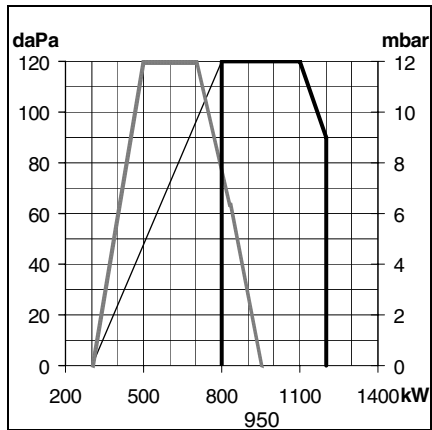

C160
 G25 P300 MBVEF 412

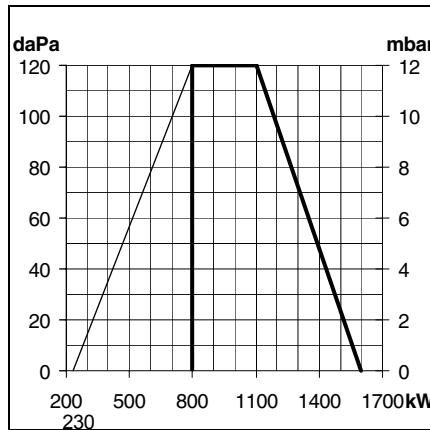

C210
 G25 P300 MBVEF 412

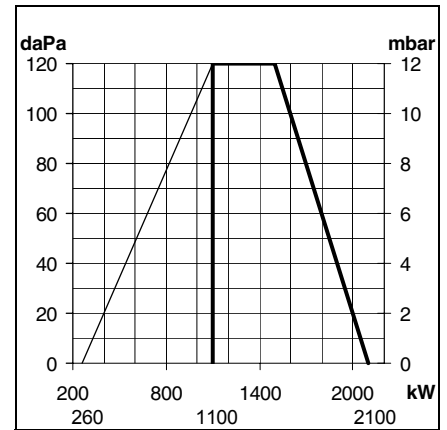

G31 P37 MBVEF 420FP
 P148 MBVEF 412

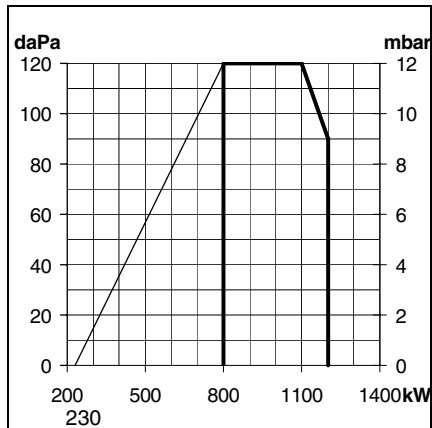

G31 P37 MBVEF 420FP
 P148 MBVEF 412

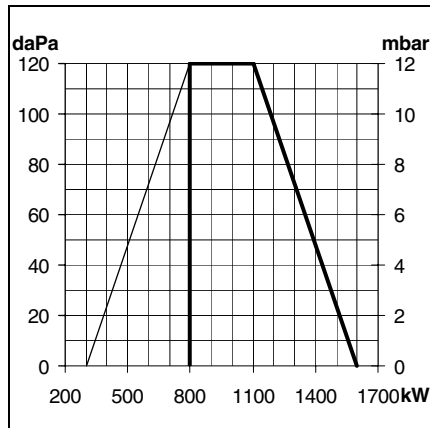

G31 P37 MBVEF 420FP
 P148 MBVEF 412

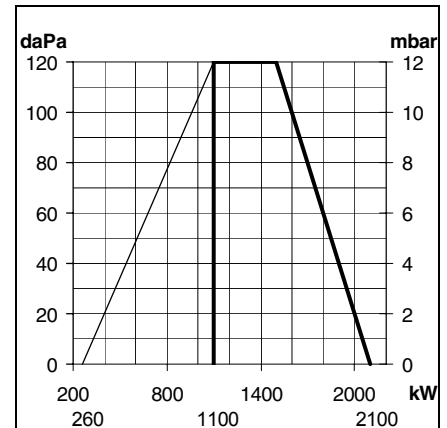

Type Tipo Típo Type Art Тип	Groupe Gruppo Grupo Group Gruppe Группа	Pression de distribution Pression de distribution Pressione di distribuzione Presión de distribución Distribution pressure Eingangsdruk Давление на входе			Hi à 0°C et 1013 mbar Hi a 0°C e 1013 mbar Hi à 0°C y 1013 mbar Hi at 0°C and 1013 mbar Hi bei 0°C und 1013mbar Hi при 0°C и 1013 мбар		Gaz Gas Gas Gas Gas Газ
		Pn mbar мбар	Pmin mbar мбар	Pmax mbar мбар	min (kWh/m ³) мин. (кВтч/м ³)	max (kWh/m ³) макс. (кВтч/м ³)	
Gaz H Gas H Газ H	2H	20 25 40 50 100 300	17 20 32 42,5 80 240	25 30 48 57,5 120 360	9,5	11,5	G20
Gaz L Gas L Газ L	2L	25 300	20 240	30 360	8,5	9,5	G25
Gaz P Gas P Газ P	3P	37 148	25 120	45 180	24,5	26,5	G31

Puissance kW Potenza kW Potencia kW Power kW Leistung kW Мощность кВт	C120 GX				C160 GX					
	min	20/25 nbar max	40/50 100/300 nbar max	37/148 nbar max	min	G20p20 nbar max	G20p25 nbar max	G20p40 nbar max	50/100 150/300 nbar max	37/148 nbar max
Brûleur (kW)	500 ... 800	950 ... 1200	1200	1200	700 ... 800	1350 ... 1500	1470 ... 1600	1420	1600	1600
Mn. allumage (kW)	230	—	—	—	—	—	—	—	—	—
Générateur (kW)	460 ... 736	874 ... 1104	1104	1104	644 ... 736	1242 ... 1380	1352 ... 1472	1306	1472	1472
Débit nominal réel de gaz a 15°C et 1013 nbar										
Naturel groupe H H =9,45 m³/h (kWh/m³)	53 ... 85	101 ... 127	127	—	74 ... 85	143 ... 159	156 ... 169	150	169	—
Naturel groupe L H =8,13 m³/h (kWh/m³)	62 ... 98	117 ... 148	—	—	86 ... 98	—	—	—	197	—
Propane P H =24,44 m³/h (kWh/m³)	20 ... 33	—	—	49	29 ... 33	—	—	—	—	65
Masse volumique kg/m³ = 198										
Brucciatore (kW)	500 ... 800	950 ... 1200	1200	1200	700 ... 800	1350 ... 1500	1470 ... 1600	1420	1600	1600
Mn. accensione (kW)	230	—	—	—	—	—	—	—	—	—
Generatore (kW)	460 ... 736	874 ... 1104	1104	1104	644 ... 736	1242 ... 1380	1352 ... 1472	1306	1472	1472
Portata nominale eff. di gas a 15°C e 1013 nbar										
Naturale gruppo H H =9,45 m³/h (kWh/m³)	53 ... 85	101 ... 127	127	—	74 ... 85	143 ... 159	156 ... 169	150	169	—
Naturale gruppo L H =8,13 m³/h (kWh/m³)	62 ... 98	117 ... 148	—	—	86 ... 98	—	—	—	197	—
Propano P H =24,44 m³/h (kWh/m³)	20 ... 33	—	—	49	29 ... 33	—	—	—	—	65
Massa volumica kg/m³ = 198										
Quemador (kW)	500 ... 800	950 ... 1200	1200	1200	700 ... 800	1350 ... 1500	1470 ... 1600	1420	1600	1600
Mn. encendido (kW)	230	—	—	—	—	—	—	—	—	—
Generador (kW)	460 ... 736	874 ... 1104	1104	1104	644 ... 736	1242 ... 1380	1352 ... 1472	1306	1472	1472
Caudal nominal real de gas a 15°C y 1013 nbar										
Natural grupo H H =9,45 m³/h (kWh/m³)	53 ... 85	101 ... 127	127	—	74 ... 85	143 ... 159	156 ... 169	150	169	—
Natural grupo L H =8,13 m³/h (kWh/m³)	62 ... 98	117 ... 148	—	—	86 ... 98	—	—	—	197	—
Propano P H =24,44 m³/h (kWh/m³)	20 ... 33	—	—	49	29 ... 33	—	—	—	—	65
Densidad kg/m³ = 198										
Burner (kW)	500 ... 800	950 ... 1200	1200	1200	700 ... 800	1350 ... 1500	1470 ... 1600	1420	1600	1600
Mn. ignition (kW)	230	—	—	—	—	—	—	—	—	—
Generator (kW)	460 ... 736	874 ... 1104	1104	1104	644 ... 736	1242 ... 1380	1352 ... 1472	1306	1472	1472
Actual gas flow rate at 15°C and 1013 nbar										
Natural group H H =9,45 m³/h (kWh/m³)	53 ... 85	101 ... 127	127	—	74 ... 85	143 ... 159	156 ... 169	150	169	—
Natural group L H =8,13 m³/h (kWh/m³)	62 ... 98	117 ... 148	—	—	86 ... 98	—	—	—	197	—
Propane P H =24,44 m³/h (kWh/m³)	20 ... 33	—	—	49	29 ... 33	—	—	—	—	65
Voluminal mass kg/m³ = 198										
Brenner (kW)	500 ... 800	950 ... 1200	1200	1200	700 ... 800	1350 ... 1500	1470 ... 1600	1420	1600	1600
Mn. Zündleistung (kW)	230	—	—	—	—	—	—	—	—	—
Kessel (kW)	460 ... 736	874 ... 1104	1104	1104	644 ... 736	1242 ... 1380	1352 ... 1472	1306	1472	1472
Effektiver Gasdurchsatz bei 15°C und 1013 nbar										
Erdgas Gruppe H H =9,45 m³/h (kWh/m³)	53 ... 85	101 ... 127	127	—	74 ... 85	143 ... 159	156 ... 169	150	169	—
Erdgas Gruppe L H =8,13 m³/h (kWh/m³)	62 ... 98	117 ... 148	—	—	86 ... 98	—	—	—	197	—
Flüssiggas P H =24,44 m³/h (kWh/m³)	20 ... 33	—	—	49	29 ... 33	—	—	—	—	65
Dichte kg/m³ = 198										
Горелка (кВт)	500 ... 800	950 ... 1200	1200	1200	700 ... 800	1350 ... 1500	1470 ... 1600	1420	1600	1600
Мин. мощность розжига (кВт)	230	—	—	—	—	—	—	—	—	—
Котел (кВт)	460 ... 736	874 ... 1104	1104	1104	644 ... 736	1242 ... 1380	1352 ... 1472	1306	1472	1472
Эффект. расход газа при 15°C и 1013 nbar (мбар)										
Прир. газ группы H H =9,45 м³/ч (кВт·ч/м³)	53 ... 85	101 ... 127	127	—	74 ... 85	143 ... 159	156 ... 169	150	169	—
Прир. газ группы L H =8,13 м³/ч (кВт·ч/м³)	62 ... 98	117 ... 148	—	—	86 ... 98	—	—	—	197	—

Puissance kW Potenza kW Potencia kW Power kW Leistung kW Мощность кВт		C210 GX					
		min	G20p20 mbar max	G20p25 mbar max	G20p40 mbar max	50/100 150/300 mbar max	37/148 mbar max
Brûleur (kW)		820 ... 1100	1570 ... 1735	1620 ... 1860	1700 ... 2100	2100	2100
Min. allumage (kW)		260	---	---	---	---	---
Générateur (kW)		754 ... 1012	1444 ... 1596	1490 ... 1711	1564 ... 1932	1932	1932
Débit nominal réel de gaz à 15°C et 10 13 mbar							
Naturel groupe H Hi =9,45	m³/h (kWh/m³)	87 ... 116	166 ... 184	171 ... 197	180 ... 222	222	---
Naturel groupe L Hi =8,13	m³/h (kWh/m³)	101 ... 135	---	---	---	258	---
Propane P Hi =24,44	m³/h (kWh/m³)	34 ... 45	---	---	---	---	86
Masse volumique kg/m³ = 1,98							
Bruciatore (kW)		820 ... 1100	1570 ... 1735	1620 ... 1860	1700 ... 2100	2100	2100
Min. accensione (kW)		260	---	---	---	---	---
Generatore (kW)		754 ... 1012	1444 ... 1596	1490 ... 1711	1564 ... 1932	1932	1932
Portata nominale eff. di gas a 15°C e 10 13 mbar							
Naturale gruppo H Hi =9,45	m³/h (kWh/m³)	87 ... 116	166 ... 184	171 ... 197	180 ... 222	222	---
Naturale gruppo L Hi =8,13	m³/h (kWh/m³)	101 ... 135	---	---	---	258	---
Propano P Hi =24,44	m³/h (kWh/m³)	34 ... 45	---	---	---	---	86
Massa volumica kg/m³ = 1,98							
Quemador (kW)		820 ... 1100	1570 ... 1735	1620 ... 1860	1700 ... 2100	2100	2100
Min. encendido (kW)		260	---	---	---	---	---
Generador (kW)		754 ... 1012	1444 ... 1596	1490 ... 1711	1564 ... 1932	1932	1932
Caudal nominal real de gas a 15°C y 10 13 mbar							
Natural grupo H Hi =9,45	m³/h (kWh/m³)	87 ... 116	166 ... 184	171 ... 197	180 ... 222	222	---
Natural grupo L Hi =8,13	m³/h (kWh/m³)	101 ... 135	---	---	---	258	---
Propano P Hi =24,44	m³/h (kWh/m³)	34 ... 45	---	---	---	---	86
Densidad kg/m³ = 1,98							
Burner (kW)		820 ... 1100	1570 ... 1735	1620 ... 1860	1700 ... 2100	2100	2100
Min. ignition (kW)		260	---	---	---	---	---
Generator (kW)		754 ... 1012	1444 ... 1596	1490 ... 1711	1564 ... 1932	1932	1932
Actual gas flow rate at 15°C and 10 13 mbar							
Natural group H Hi =9.45	m³/h (kWh/m³)	87 ... 116	166 ... 184	171 ... 197	180 ... 222	222	---
Natural group L Hi =8.13	m³/h (kWh/m³)	101 ... 135	---	---	---	258	---
Propane P Hi =24.44	m³/h (kWh/m³)	34 ... 45	---	---	---	---	86
Voluminal mass kg/m³ = 1,98							
Brenner (kW)		820 ... 1100	1570 ... 1735	1620 ... 1860	1700 ... 2100	2100	2100
Min. Zündleistung (kW)		260	---	---	---	---	---
Kessel (kW)		754 ... 1012	1444 ... 1596	1490 ... 1711	1564 ... 1932	1932	1932
Effektiver Gasdurchsatz bei 15°C und 10 13 mbar							
Erdgas Gruppe H Hi =9,45	m³/h (kWh/m³)	87 ... 116	166 ... 184	171 ... 197	180 ... 222	222	---
Erdgas Gruppe L Hi =8,13	m³/h (kWh/m³)	101 ... 135	---	---	---	258	---
Flüssiggas P Hi =24,44	m³/h (kWh/m³)	34 ... 45	---	---	---	---	86
Dichte kg/m³ = 1,98							
Горелка (кВт)		820 ... 1100	1570 ... 1735	1620 ... 1860	1700 ... 2100	2100	2100
Мин. мощность розжига (кВт)		260	---	---	---	---	---
Котел (кВт)		754 ... 1012	1444 ... 1596	1490 ... 1711	1564 ... 1932	1932	1932
Эффект. расход газа при 15°C и 1013 mbar (мбар)							
Прир.газ группы H Hi =9,45	m³/ч (кВтч/м³)	87 ... 116	166 ... 184	171 ... 197	180 ... 222	222	---
Прир.газ группы L	m³/ч	101 ... 135	---	---	---	258	---

Composition de la rampe gaz
Composizione della rampa gas
Composición de la rampa de gas
Gas manifold composition
Zusammensetzung der Gasarmatur
Газорегулирующая арматура

Brûleur Bruciatore Quemador Burner Brenner Горелка	Gaz Gas Gas Gas Gas Газ	P gaz P Gas P Gas P Gas P Gas Газ П mбар мбар	P max kW кВт	Vanne Valvola Válvula Valve Ventil Клапан			Contrôleur étanchéité Controllore tenuta Control. estanqueidad Leakage test unit Dichtheitskontroll Контроль утечек VPS...	Filtre Filtro Filtro Filter Filter Фильтр			Pressostat Pressostato Presostato Press. Switch Druckwächter Реле давления GW....		
				MB VEF...	VGD...	Ø bride Ø brida Ø brida Ø flange Ø Flansch Ø фланец Rp		intégré incorp. integrado integrated interner внутр.	extérieur externo external external externer наружный	poche tasca bolsa pocket Taschen карман ный FP			
C 120	G20	20	950	420		2	504 S 02	FI		FP	150 A5		
			1120		20.507	DN50			DN50		150 A4		
		1200	25	420		2				FP	150 A5		
			20		40.065	DN65				DN65	150 A4		
			25		20.507	DN50				DN50	150 A4		
			25		40.065	DN65				DN65	150 A4		
			40	420		2					FP	150 A5	
			50	420		2						150 A5	
			100	412		1 ¼				FI	2	150 A5	
			150	412		1 ¼					2	150 A5	
	300	412		1 ¼				2	150 A5				
	G25	25	950	420		2				FP	150 A5		
		300	1200	412		1 ¼		FI	2		150 A5		
	G31	37	1200	420		2				FP	150 A5		
		148		412		1 ¼		FI	2		150 A5		
C 160	G20	20	1350		40.065	DN65	504 S 02		DN65		150A4		
			40	1420	420				2		FP	150A5	
		1500	25	1470		40.065			DN65	DN65	150A4		
			20		40.080	DN80			DN80	150A4			
			25		40.080	DN80			DN80	150A4			
			50		20.507	DN50			DN50	150A4			
		1600	50	420		2					FP	150A5	
			100	420		2						150A5	
			150	420		2						150A5	
			300	412		1 ¼				FI	2	150A5	
	G25		300	412		1 ¼			FI	2	150A5		
		G31	37	1600	420			2			FP	150A5	
	148		412			1 ¼		FI	2		150A5		
	C 210	G20	20	1570		40.065		DN65	504 S 02		DN65		150A4
				25	1620			40.065			DN65	DN65	150A4
1700			40		20.507	DN50	DN50	150A4					
			20	1735		40.080	DN80	DN80			150A4		
			25	1860		40.080	DN80	DN80			150A4		
			40		40.065	DN65	DN65	150A4					
2100			50	425		2		2			150A5		
			100	420		2					FP	150A5	
			150	420		2						150A5	
			300	412		1 ¼		2			150A5		
		G25	300	412		1 ¼		2		150A5			
G31			37		420		2			FP	150A5		
		148	412			1 ¼		2			150A5		

Encombrement Dimensions
Dimensioni d'ingombro
Dimensiones Medidas
Space requirements and dimensions
Мабилд и Абмессунгн
Чертеж с размерами

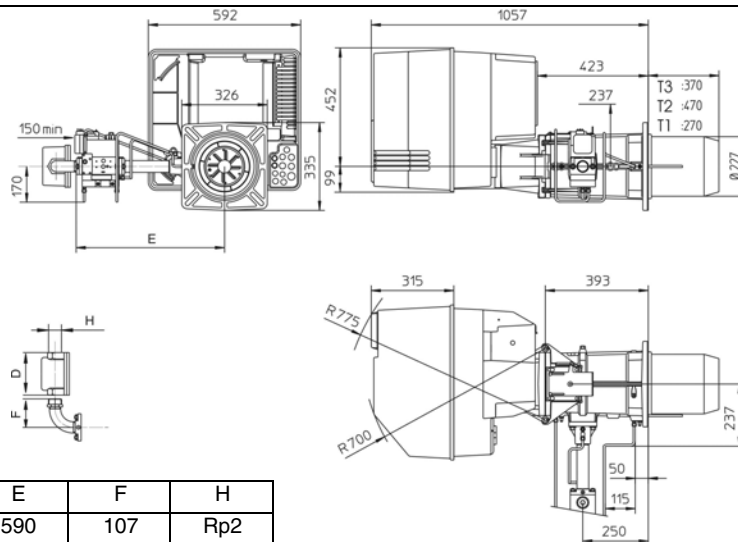

	D	E	F	H
MBVEF 412	160	590	107	Rp2
MBVEF 420	—	690	—	—
MBVEF 425	160	650	107	Rp2

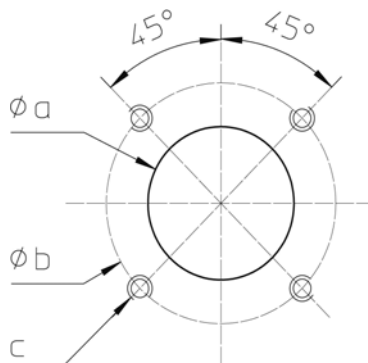
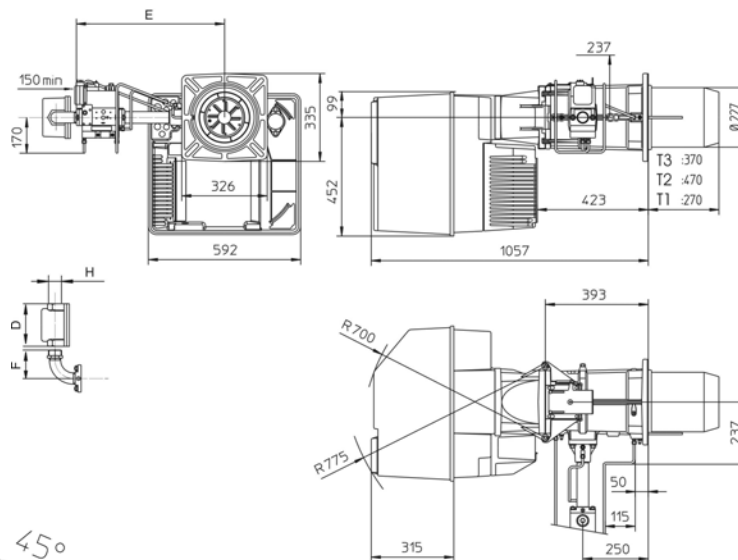

En gras Ø recommandé
 In grassetto: Ø consigliato
 En negrita Ø recomendado
 Highlighted: recommended Ø
 empfohlen Ø fettgedruckt
 Жирным шрифтом Ø указан рекомендуемый диаметр

Ø a	Ø b	c
250	300 - 400	M12

Encombrement et dimensions

Respecter une distance libre minimum de 0,60 mètre de chaque côté du brûleur pour permettre les opérations de maintenance.

Ventilation chaufferie

Le volume d'air neuf requis est de 1,2 m³/kWh produit au brûleur.

Rampe gaz

S'implante uniquement à l'horizontale à droite ou à gauche.

Dimensioni d'ingombro

Lasciare uno spazio libero minimo di 0,6 metri su ogni lato del bruciatore per consentire le operazioni di manutenzione.

Ventilazione locale caldaia

La portata dell'aria di ricambio del locale deve essere almeno di 1,2 m³/kWh bruciatore.

Rampa gas

Deve essere installata unicamente in orizzontale a destra o a sinistra.

Dimensiones y Medidas

Respetar una distancia libre mínima de 0,6 metros a ambos lados del quemador para permitir las operaciones de mantenimiento.

Ventilación calentador

El volumen de aire nuevo requerido es de 1,2 m³/kWh producido en el quemador.

Rampa de gas

Sólo se coloca en horizontal a la derecha o a la izquierda

**Encombrement Dimensions
Dimensioni d'ingombro
Dimensiones Medidas
Space requirements and dimensions
Maßbild und Abmessungen
Чертеж с размерами**

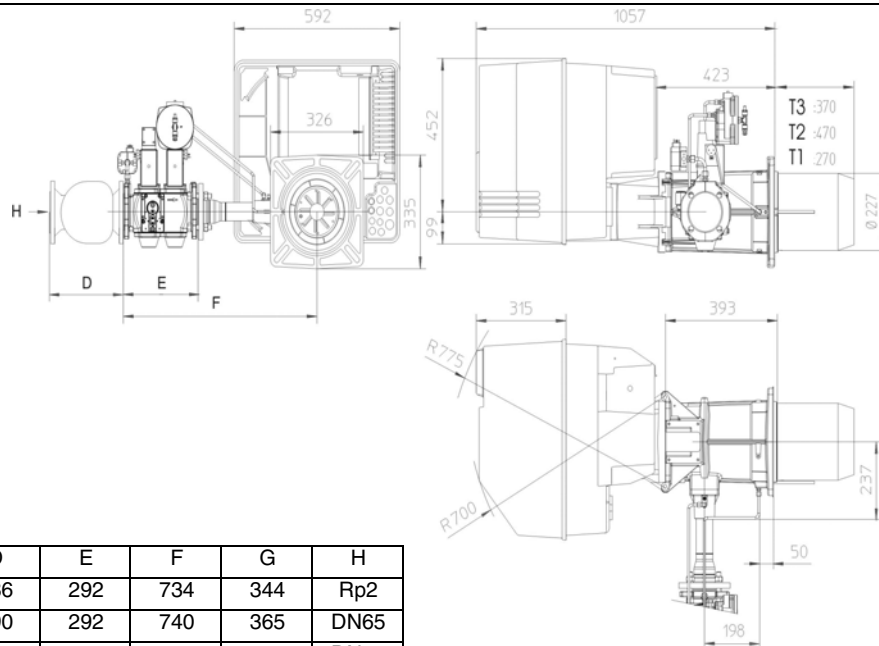

	D	E	F	G	H
VGD20.507	186	292	734	344	Rp2
VGD40.065	290	292	740	365	DN65
VGD40.080	320	312	746	375	DN80

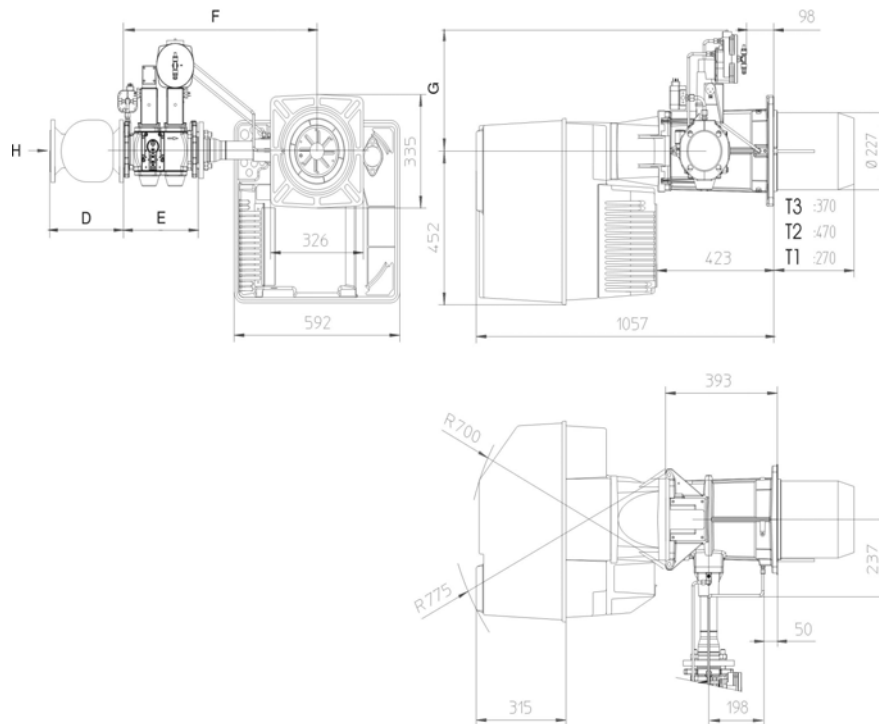

Space requirements and dimensions
Leave a space of at least 0.6 metres on each side of the burner for maintenance purposes.

Boiler-house ventilation
Volume of fresh air required is 1.2 m³/kWh produced at the burner.

Gas manifold
Can only be installed horizontally, on the **right** or on the left.

Maßbild und Abmessungen
Für Servicearbeiten ist ein freier Abstand von min. 0,6m auf jeder Seite des Brenners sicherzustellen.

Heizraumbelüftung
Die nötige Frischluftzufuhr beträgt 1,2 m³/kWh am Brenner.

Gasarmaturgruppe
Montage waagrecht **rechts** oder links möglich

Чертеж с размерами
Для техухода с каждой стороны горелки должно быть оставлено свободное место как минимум 0,6 м.

Вентиляция котельного помещения
Подача свежего воздуха должна составлять 1,2 м³/кВтч мощности горелки.

Газорегулирующая арматура
Возможен горизонтальный монтаж **справа** или слева.



Pièces de rechange
Pezzi di ricambio
Piezas de recambio
Spare parts list
Ersatzteilliste
Список запчастей

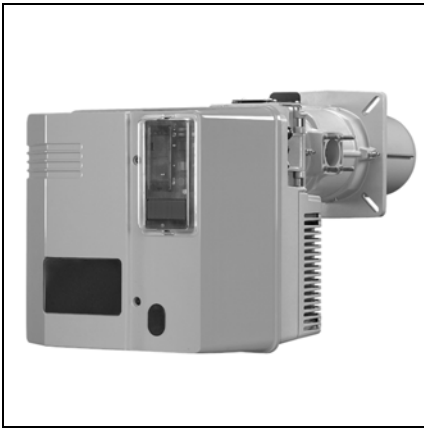

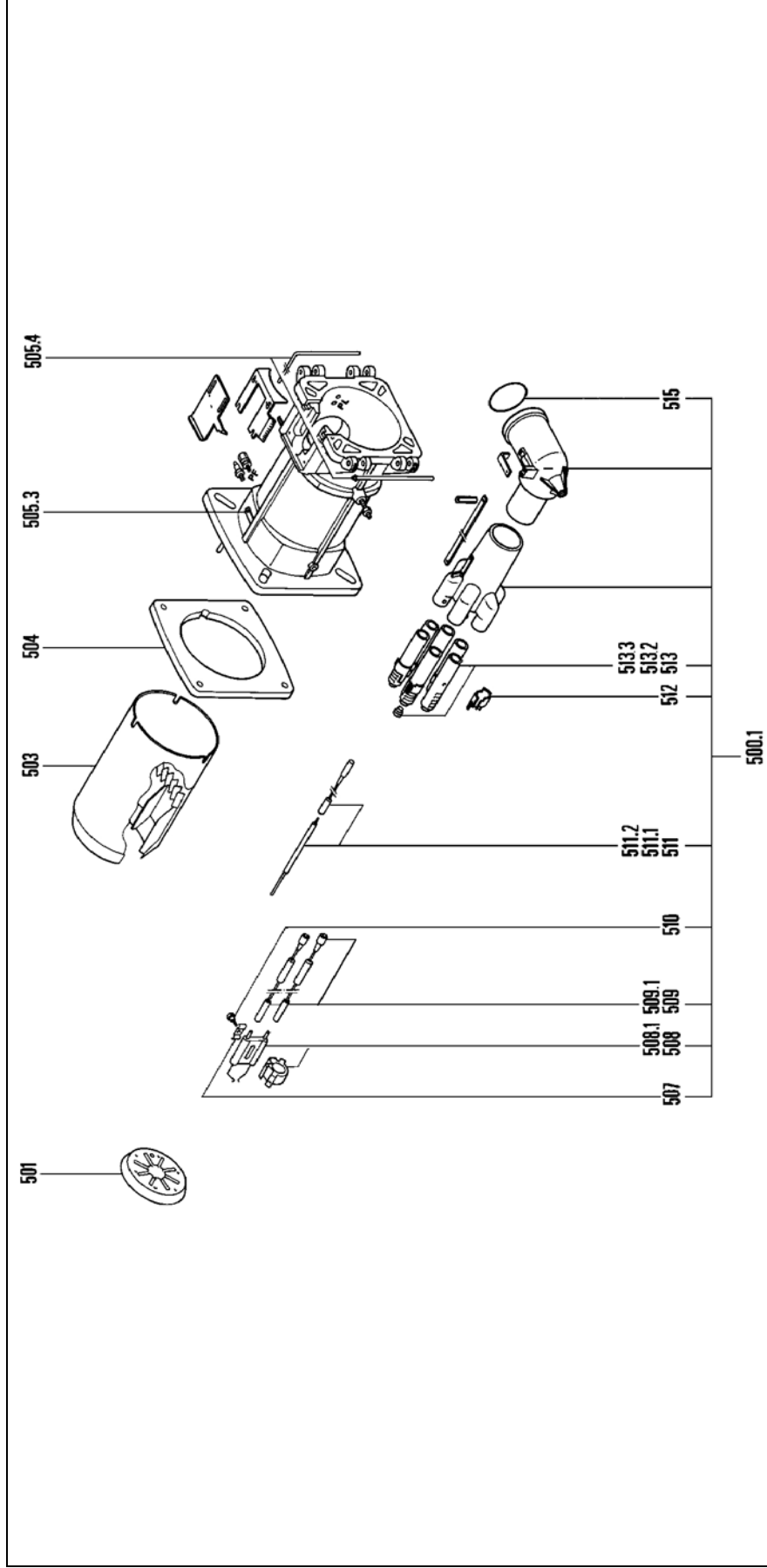

Pos.	Désignation simplifiée	Denominazione	Designación simplificada	Description	Bezeichnung	Название	Art. Nr.
	Désignation simplifiée C160 = 160 C210 = 210	Descrizione semplificata	Denominación simplificada	Simplified designation	Symboldarstellung	Упрощенное обозначение	
500.1	Coude gaz équ. T1 T2 T3			Lance gas head kpl.	Lanzengaskopf BG	Газовая линия	13 010 051 13 010 052 13 010 053
501	Défecteur 120/160Ø168/50- 8FD.+7Ø5 210 Ø125/40-9FD.+6Ø5	Deflettore	Deflector	Turbulator	Turbulator	Турбулятор	13 015 783 13 015 777

Pos.	Désignation	Denominazione	Designación	Description	Bezeichnung	Название	Art. Nr.
503	Embout 120/160 Ø190/172/227 x 343 T1 x 543 T2 x 443 T3 210 Ø205/160/227 x 343 T1 x 543 T2 x 443 T3	Imbuto	Cañon del quemador	Blast tube	Flammenrohr	Жаровая труба	13 015 910 13 015 914 13 015 912 13 015 916 13 015 918 13 015 917
504	Joint/façade chaudière	Guarnizione	Junta	Flange Klingerit	Dichtung	Уплотнение	13 016 239
505.3	Vis embase M8x20/embout 3x	Flangia base M8x20/ imbuto	Tornillo M8x20/cañon	Screw M8x20/blast tube	Schraube M8x20/ Flammenrohr	Винт M8x20/ жаровая труба	13 009 723
505.4	Axes (fixe+mobile)	Perni (fisso+mobile)	Ejes (fijo+móvil)	Axes	Fueh Bolzen set	Ось (фиксируемая + подвижная)	13 015 548
507	Bride/électrode	Flangia/elettrodo	Brida/electrodo	Electrode fix. plate	Klemmfeder	Зажимная пружина	13 009 725
508	Electrode allu (bloc blanc)x	Elettrodo acc. (blocco bianco)	Electrodo enc. (bloque blanco)	Electrode (white block)	Elektroden (weiß)	Электрод (белый)	13 015 855
508.1	Support électrode & sonde	Support elettrodo	Soporte electrodo	Electrode/ioni.support	Halterung/Elekt.+ Fühler	Держатель для электрода + зонд	13 010 050
509	Câble allu./tête L.950 2x	Cavo acc./testa	Cable encendido/cabeza	Ignition lead	Zündkabel	Розжиговый кабель	13 015 645
509.1	Fiche ronde Ø6.4 2x			Round plug Ø6,4	Rundstecker Hülse Ø6,4	Круглый штекер диаметром 6.4	13 010 056
510	Vis épaulée M4/électrode	Vite con colletto M4/elett.	Tornillo con cabeza de arandela M4/electr.	Screw M4/electrode	Schraube M4/Elektrode	Винт M4/электрод	13 010 049
511	Sonde d'ionisation	Sonda di ionizzazione	Sonda ionización	Ionisation probe	Ionisationsstab	Ионизационный зонд	13 016 582
511.1	Câble ionisation / tête de combustion L.950			Ionisation cable / combustion head L.950	Ionisationskabel / Brennkopf L. 950	Ионизационный кабель/ головка горелки L.950	13 015 620
511.2	Bride / sonde ionisation	Flangia / Sonda di ionizzazione	Brida / Sonda ionización	Probe fixing plate	Klemmferder / Ionisationsstab	Зажимная пружина / ионизационный зонд	13 010 054
512	Obturbateur/diffuseur 6x	Otturatore/diffusore	Obturbador/difusor	Gas ring/diffusor	Gashülse/Gasdüse	Газовая гильза / газовое сопло	13 010 046
513	Diffuseurs complets 6x	Diffusore	Difusor	Diffusor kpl.	Gasdüsen BG	Газовые сопла	13 010 047
513.2	Kit vis gaz naturel			Natural gas screws set	Erdgas Schraubenset	Комплект винтов (природный газ)	13 010 048
513.3	Kit vis gaz propane			Propane gas screws set	Flüssiggas Schraubenset	Комплект винтов (пропан)	13 007 041
515	Joint torrique/coude gaz	Guarnizione torica/gomito gas	Junta tórica/codo gas	O Ring/lance gas head	O' Ring/Lanzengaskopf	Кольцо круглого сечения/головка трубки сопла	13 016 221



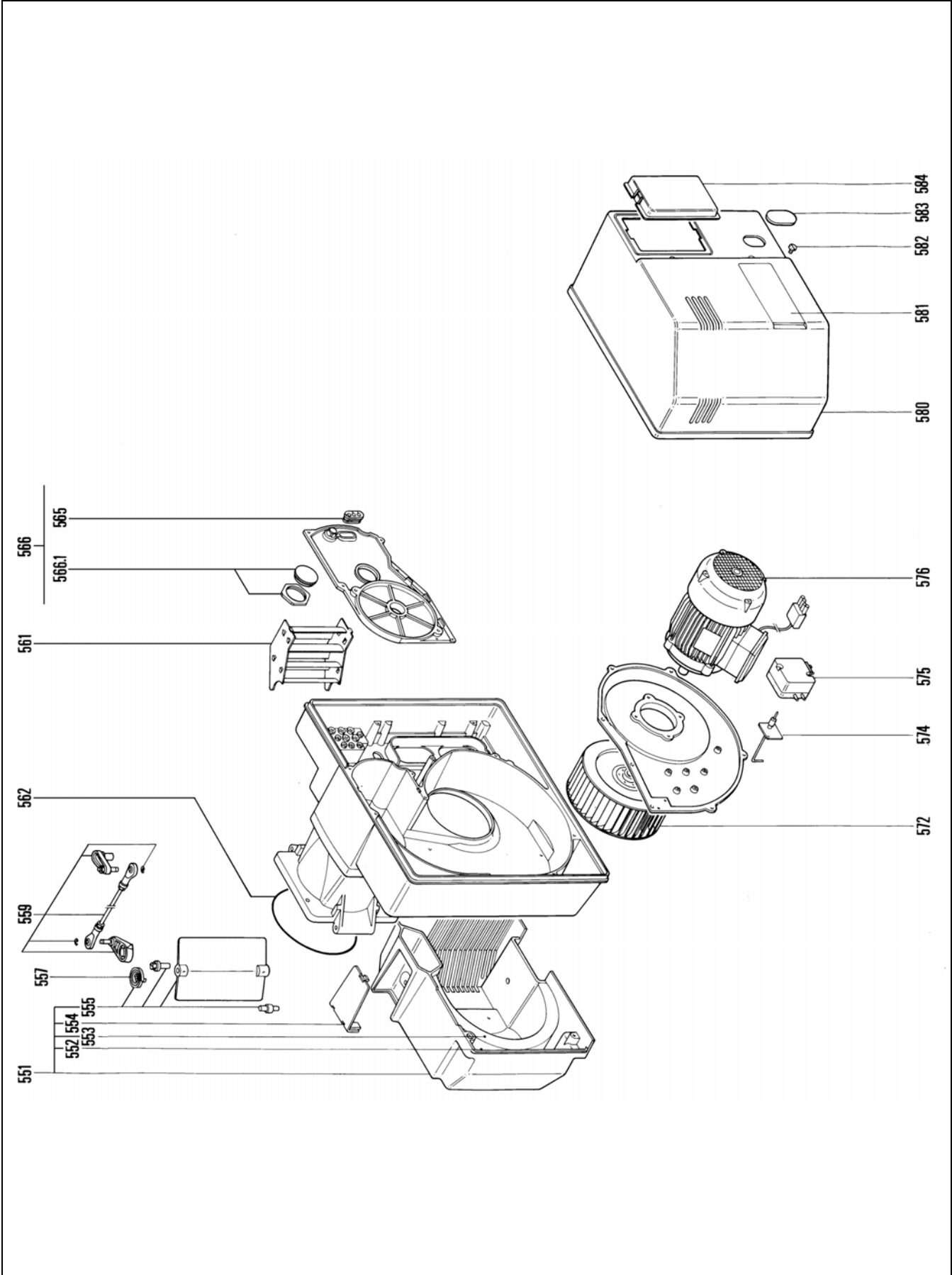

Pos.	Désignation	Denominazione	Designación	Description	Bezeichnung	Название	Art. Nr.
551	Boîte à air éq.	Scatola d'aria completa	Caja de aire completa	Air damper cpl.	Luftkasten BG	Воздушный короб BG	13 011 565
552	Joint boîte à air/carter	Guarniz.scatola aria/carter	Junta de caja de aire/carter	Seal air damper/casing	Dichtband Luftk. / BG	Уплотнительная лента для воздушного короба/BG	13 009 640
553	Isolation/boîte à air	Isolam.scatola aria	Aislamiento/caja de aire	Insulation air damper cover	Isolierung/Luftkasten	Изоляция / воздушный короб	13 009 641
554	Couvercle/boîte à air	Coperchio/scatola aria	Tapa/caja de aire	Air damper cover	Deckel / Luftkasten	Крышка / воздушный короб	13 009 642
555	Volet d'air complet	Serranda aria cpl.	Mariposa de aire cpl.	Air flap cpl.	Luftklappe BG	Воздушная заслонка	13 014 117
557	Ressort plat/volet d'air			Flat spring/flap	Feder/Luftklappe	Пружина / воздушная заслонка	13 011 751
559	Accouplement équipé	Accopiam. completo	Acoplamiento ec.	Coupling cpl.	UE.-St. m. Winkelgelenk	Муфта	13 011 835
561	Redresseur d'air	Traddizzatore d'aria	Rectificador de aire	Recycling air	Luftleitschaukel	Рециркуляция воздуха	13 009 748
562	Joint carter			Burner housing seal	Dichtung-Gehäuse	Уплотнительная прокладка картера	13 010 055
565	Passe fils	Passafili	Pasacables	Rubber funnel	Tülle-Kabeldurchführ.	Ввод для кабеля	13 009 648
566	Couvercle éq.			Cover	Deckel BG	Крышка (с комплектующими)	13 010 036
566.1	Voyant de flamme éq.	Spia della fiamma comp.	Piloto de llama comp.	Sight glass cpl.	Schauglas kpl.	Сигнальная лампа пламени (с комплектующими)	13 010 008
572	Turbine 120/160 Ø 240 x 114 210 Ø 250 x 114	Turbina	Turbina	Air fan	Ventilatorrad	Колесо вентилятора	13 009 736 13 009 737
574	Prise pression différentielle			Differential pressure tapping	Differentialdrucknippel	Ниппель дифференциального давления	13 009 738
575	Pressostat LGW 3 A2	Pressostato	Presostato	Press.contr.device	Druckwächter	Реле давления	13 010 111
576	Moteur 230/400V / turbine 120/160 2,2 kW Ø 210 2,7 kW Ø	Motore/turbina	Motor/turbina	Motor/air fan	Motor/Ventilatorrad	Двигатель/Колесо вентилятора	13 016 371 13 016 372
580	Capot orange équipé	Coperchio arancione	Tapa naranja	Cover	Schutzhaube kpl	Звукоизолирующий колпак	13 001 338
581	Plaque frontale 120 160 210	Thargetta frontale	Placa frontal	Front plate	Beschriftungsplatte	Маркировочная табличка	13 016 416 13 016 417 13 016 418
582	Vis/capot 2x	Vite/coperchio	Tornillo/tapa	Oval head screw	Flachkopfschraube	Винт/крышка	13 009 657
583	Obturateur/capot	Otturatore/coperchio	Obturador/tapa	Cap/cover	Abdeckung/Haube	Демпирование/крышка	13 009 742
584	Couvercle du TC	Coperchio del TC	Tapa del TC	Transparent cap/cover	Klarsichtdeckel-Schutz	Прозрачная крышка/крышка	13 009 659



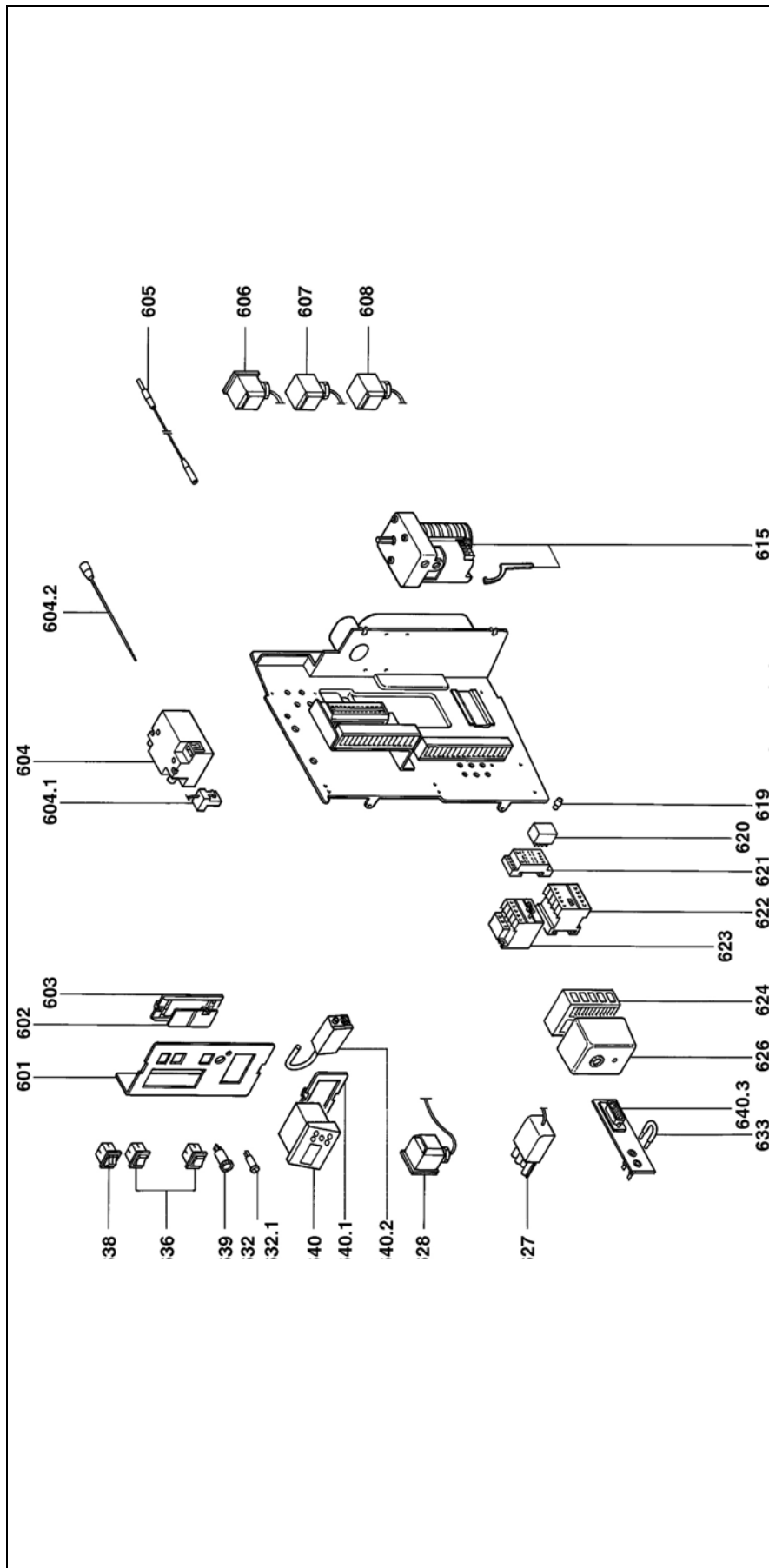

Pos.	Désignation	Denominazione	Designación	Description	Bezeichnung	Название	Art. Nr.
601	Pupitre de commande	Quadro di mando	Pupitre de mando	Control board	Zentralschaltpult	Панель управления	13 014 002
602	Obturbateur/support régul.	Otturatore/supp.regolati.	Obturbador/soporte regul.	Translucent seal/base	Abdeckung/Entriegel/ platte	Крышка/ деблокирование/ основание	13 009 661
603	Support régulation	Supporto regolazione	Soporte regulación	Regulation base	Regulierungssockel	Регулируемое основание	13 009 662
604	Transformateur 2 x 7,5kV	Trasformatore	Transformador	Ignition transfo.	Zündtrafo	Трансформатор розжига	13 009 663
604.1	Prise C.2P.+câble/transfo.	Prise C.2P. + cavo/trasf.	Toma C.2P.+ cable/ transformador	2P. Bent/cable transfo.	geb. 2P./Zündkabel	Штекер 2-полюсный 2P + кабель трансформатора	13 009 773
604.2	Câble allu./Corps L7502x	Cavo acc./corpo	Cable encendido/cuerpo	Ignition lead/casing L750	Zündkabel/ Gebliaseteil BG L750	Розжиговый кабель / Корпус L750	13 009 727
605	Câble ion./corps L750			Ionisation cable	Ionisationskabel	Ионизационный кабель/ корпус L750	13 009 744

Pos.	Désignation	Denominazione	Designación	Description	Bezeichnung	Название	Art. Nr.
606	Prise + câble/pressostat gaz	3P./pressostato gas	3P./presostato gas	3P./gas pressure switch	3P./Gasdruckwächter	3 полюса 3P./ Реле давления газа	13 011 839
607	Prise + câble/vanne gaz	3P./valvola gas	3P./válvula gas	3P./gas valve	3P./Gasventil	3 полюса 3P./ Газовый клапан	13 009 666
608	Prise + câble/régulateur SKP	Servomotore	Servomotor	3P./governor SKP "X5"	3P./SKP Regler	3 полюса 3P./регулятор SKP	13 014 162
615	Servomoteur SQN 31 481 A2766	Servomotore	Servomotor	Servomotor	Stellantrieb	Сервопривод	13 016 565
619	Capuchon sautochouc	Capuchio goma	Capuchón de goma	Rubber cap	Gummikappe	Резиновый колпачок	13 009 625
620	Relais Finder 2RT 55.34	Relè	Relé	Finder relay	Finder Relais	Реле Finder	13 017 722
621	Socle relais Finder 55.34	Base relè	Base relé	Finder relay base	Finder Relaissockel	Основание реле Finder	13 017 721
622	Relais thermique T. LR 2K 400V 5,5 - 8,0A	Relè termico	Relé térmico	Relay motor prot.	Motorschützrelais	Реле контактора двигателя	13 009 746
623	Contacteur T. LC 1K	Contactore	Contacto	Contacto	Motorschütz	Контактор двигателя	13 009 778
624	Socle coffret	Base programm. comando	Base cajetín	Control box base	Relaissockel	Цоколь реле	13 009 797
626	Partie active SG 5xx	Parte attiva	Parte activa	Control box SG 5xx	Relais SG 5xx	Реле SG 5xx	13 011 099
627	4P.L600 /mot. ventilation	4P.L600 /motore ventilaz.	4P.L600 /motor ventilación	4P.L600 /fan motor	4 P.L600 /Gebläsemotor	4-пол. L600 / двигатель вентилятора	13 009 782
628	Prise + câble/pressostat air	2P./pressostato aria	2P./presostato aire	2P./air pressure switch	2P./Luftdruckwächter	3-пол. L1200 / реле давления воздуха	13 011 623
632	Porte fusible + fusible	Portafusibile+fusibile	Portafusibles+fusibles	Fuse carrier	Sicherungssatz	Предохранительный комплект	13 016 457
632.1	Fusible 5x20 6,3Afus. lente	Fusibile fus.lenta	Fusible fus. lento	Fuse fine	Feinsicherung	Слаботочный предохранитель 5x20 6,3A	13 016 028
633	Pont de mesure [µA DC]	Ponte di misura	Puente de medición	Connexion for mesure	Meßbrücke	Измерительный мост (постоянный ток)	13 010 019
636	Interrupteur 3 pos. 2x	Interruttore 3 pos.	Interruptor 3 pos.	Operating switch 3 pos.	Betriebsschalter	Рабочий выключатель 3 поз.	13 009 683
638	Interrupt. double lumi. 2 pos.			Operating switch 2 pos.	2-Positionsschalter	Рабочий выключатель 2 поз.	13 009 787
639	Bouton poussoir lumi. réarm.			Restart push button	Entriegelungstaster	Деблокирующая кнопка	13 015 580
640	Afficheur IR			IR display	IR-Anzeige	Инфракрасный дисплей	13 011 617
640.1	Support afficheur			Display stand	Aneigehalter	Опора дисплея	13 009 684
640.2	Bloc alim. 230VAC/9VDC/af.			Display power supply unit	Anzeigenetzgerät	Блок питания дисплея 230 В перемен. ток /9В пост. ток	13 011 618
640.3	Prise équipé DB9			DB9 socket	DB9 Stecker	Штекер DB9	13 011 619
	Kit afficheur	Schermo kit	Cartles kit	Set display	Set Anzeige	Комплект для дисплея	13 007 610



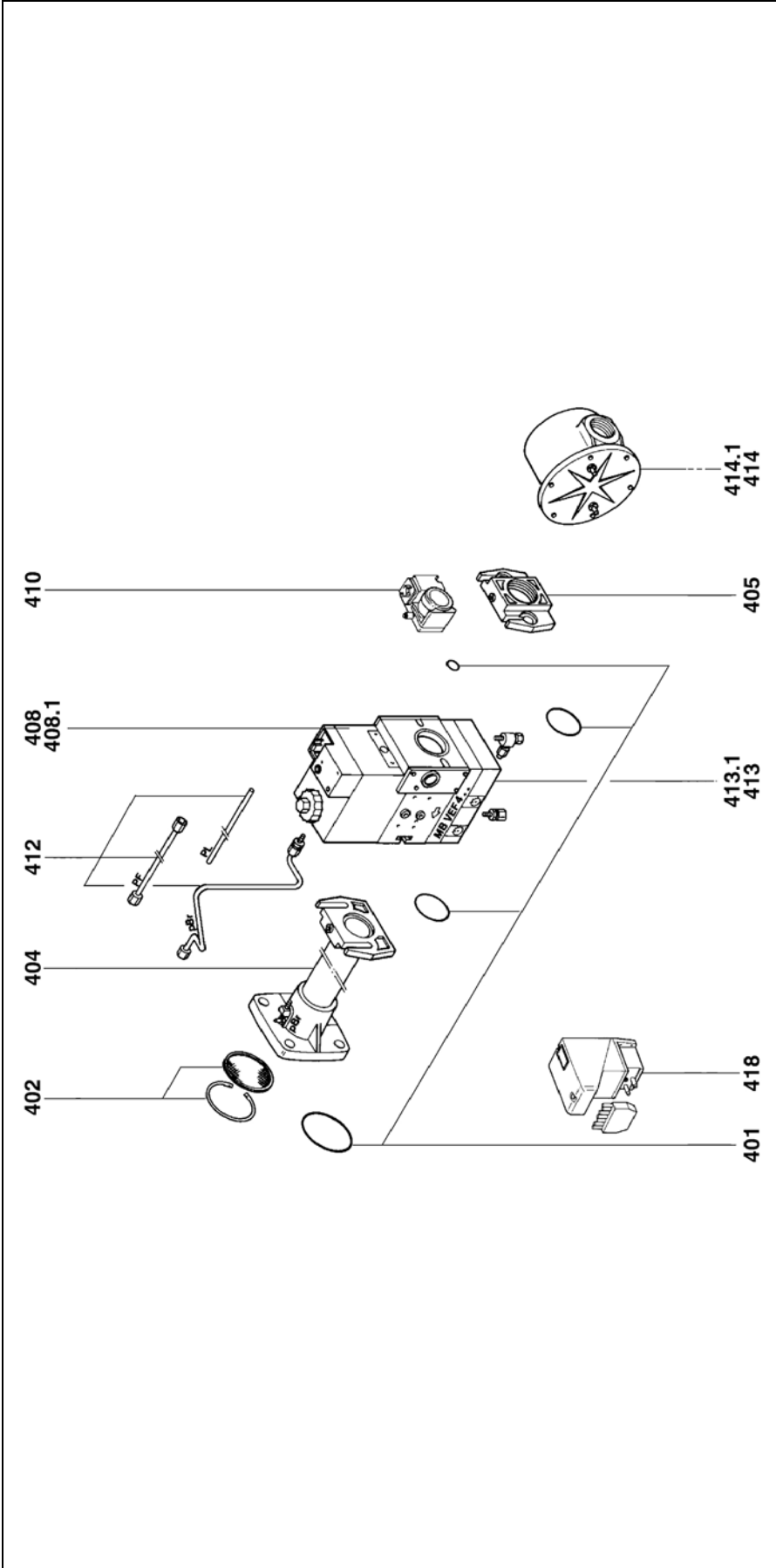

Pos	Désignation	Denominazione	Designación	Description	Bezeichnung	Название	Art. Nr.
401	Kit Joint torique MBVEF 412 425	Kit Guarniz. torica/flangia	Kit Junta tórica/brida	O'Ring/flange Set	O'Ring/Flansch Set	Кольцо круглого сечения / фланец	13 011 366 13 011 368
402	Circlips + stabilisateur Ø 60	Fermaglio + stabilizzatore	Grupillas + estabilizador	Circlips + stabilizer	Ring + Stabilisator	Предохранительное кольцо + стабилизатор	13 011 367
404	Collecteur monté Rp 1,1/4 Rp 2	Flangia/collettore	Brida/colector	Flange/gas tube	Flansch/Gasrohr	Фланец/газовая труба	13 014 122 13 014 123
405	Bride / MB... 412 Rp 1,1/4 420 Rp 2	Brida/MB	Brida/MB	MB flange	Flansch/MB	Фланец/MB...	13 015 586 13 014 124
408	Vanne MB VEF 412 B01 S30 + FI MB VEF 425 B01 S10 + FI	Valvola	Válvula	Valve	Ventil	Клапан	13 016 722 13 016 726
408.1	Bobine VS. + VA 412 n° 1205 425 n° 1415	Bobina	Bobina	Magnet coil VS + VA	Magnetspule	Магнитная катушка	13 015 560 13 015 563
409	Joint torique/press. & VPS	Guarniz.torica/press. e VPS	Junta tórica/pres. y VPS	O'Ring/press.	O'Ring/Druckwächter	Кольцо круглого сечения / реле давления VPS	13 016 217
410	Pressostat GW 150 A5	Pressostato	Pressostato	Press. cont. device	Druckwächter	Реле давления	13 016 461
412	Tubes PL+PF G/D. + Pbr 412 425	Tubi PL+PF G/D. + Pb	Tubos PL+PF G/D. + Pb	Pressure feed PL+PF L/R. + Pbr	Rohrdruck PL+PF L/R. + Pbr	Трубки PL+PF G/D.	13 014 125 13 014 126
413	Tamis 412 425	Filtro	Tamiz	Screen	Sieb	Фильтр	13 016 012 13 014 127
413.1	Joint plat couv. tamis	Guarnizione	Junta	Fiat seal/screen cover	Flachdichtung/ Siebdeckel	Плоское уплотнение / крышка фильтра	13 011 722
414	Filtre extérieur Anello Rp 2	Filtro esterno	Filtro exterior	External filter	äußeres Filter	Наружный фильтр	13 009 700
414.1	Élément filtrant Anello Rp 2	Elemento filtrante	Elemento filtrante	Stainer element	Filtereinsatz	Фильтрующий элемент	13 015 864
418	Contrôleur d'étanchéité 160-210 VPS 504 S02	Controllore di tenuta	Controlador de estanqueidad	Tightness control	Dichteprüfgerät	Орган контроля утечек	13 002 666



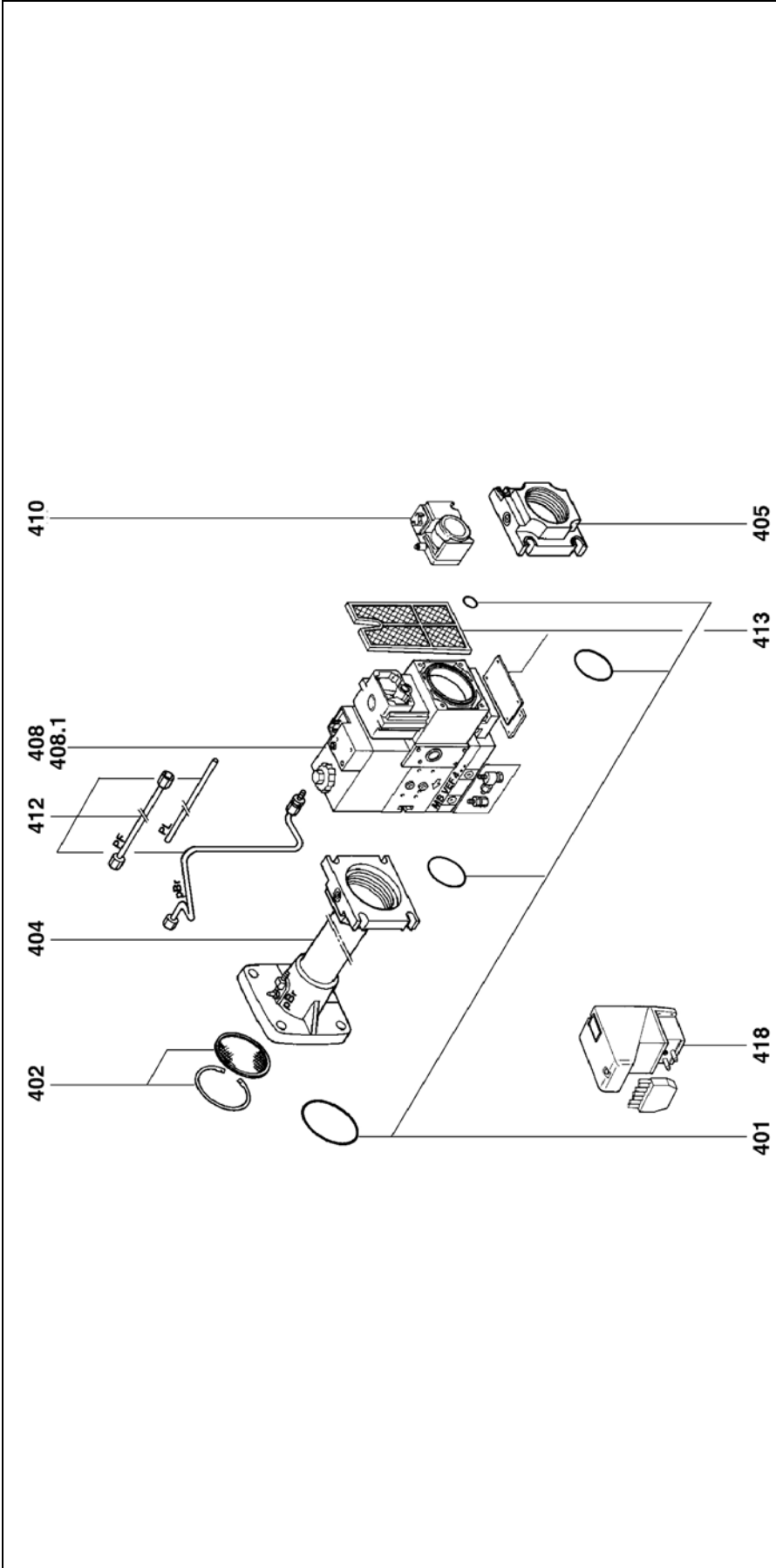

Pos	Désignation	Denominazione	Designación	Description	Bezeichnung	Название	Art. Nr.
401	Kit joint O'Ring MBVEF 420	Set guarnizioni O'Ring	Set junta O'Ring	O'Ring set	O'Ring set	Кольцо круглого сечения, комплект	13 011 368
402	Circlips + stabilisateur	Fermaglio + stabilizzatore	Grupillas + estabilizador	Circlips + stabilizer	Ring + Stabilisator	Предохранительное кольцо + стабилизатор	13 011 367
404	Collecteur monté Rp 2	Collettore mont.	Colector	Gas tube	Anschlußflansch	Соединительный фланец	13 014 128
405	Bride / MBVEF 420	Brida / MBVEF 420	Brida / MBVEF 420	MB Flange	Flansch/MB	Фланец	13 007 859
408	Vanne MB VEF 420 B01 S10	Valvola	Válvula	Valve MBVEF	Gasarmatur MBVEF	Клапан MB VEF	13 016 725
408.1	Bobine VS + VA n°1215	Bobina	Bobina	Magnetic coil	Magnetspule	Магнитная катушка	13 011 726
409	Joint O'Ring/press./VPS 2x	Guarniz.torica/pres./VPS x2	Junta tórica/pres./VPS x2	O'Ring /press./VPS 504	O'Ring/Druckw./VPS504	Кольцо круглого сечения/реле давления/VPS504	13 016 217
410	Pressostat GW 150 A5	Pressostato	Pressostato	Press. cont. device	Druckwächter	Реле давления	13 010 078
411	Manomètre 0-60 mbar	Manometro	Manometro	Pressure gauge 0-60 mbar	Manometer 0-60 mbar	Манометр 0-60 мбар	13 011 721
412	Tubes PL+PF G.D.+ Pbr	Tubi	Tubos	Pressure feed PL+PF L.R. + Pbr	Rohrdruck PL+PF L.R. + Pbr	Трубки PL+PF G/D. + Pbr	13 014 129
413	Element filtrant + joint	Elemento filtrante + guarnizione	Elemento filtrante + junta	Filter element + seal	Filtereinsatz-Set	Фильтрующий элемент, комплект	13 007 901
418	Contrôleur d'étanchéité VPS504 S02	Controllo dell tenuta	Control de estanqueidad	Tightness control	Dichtprüfgerät	Орган контроля утечек	13 001 778



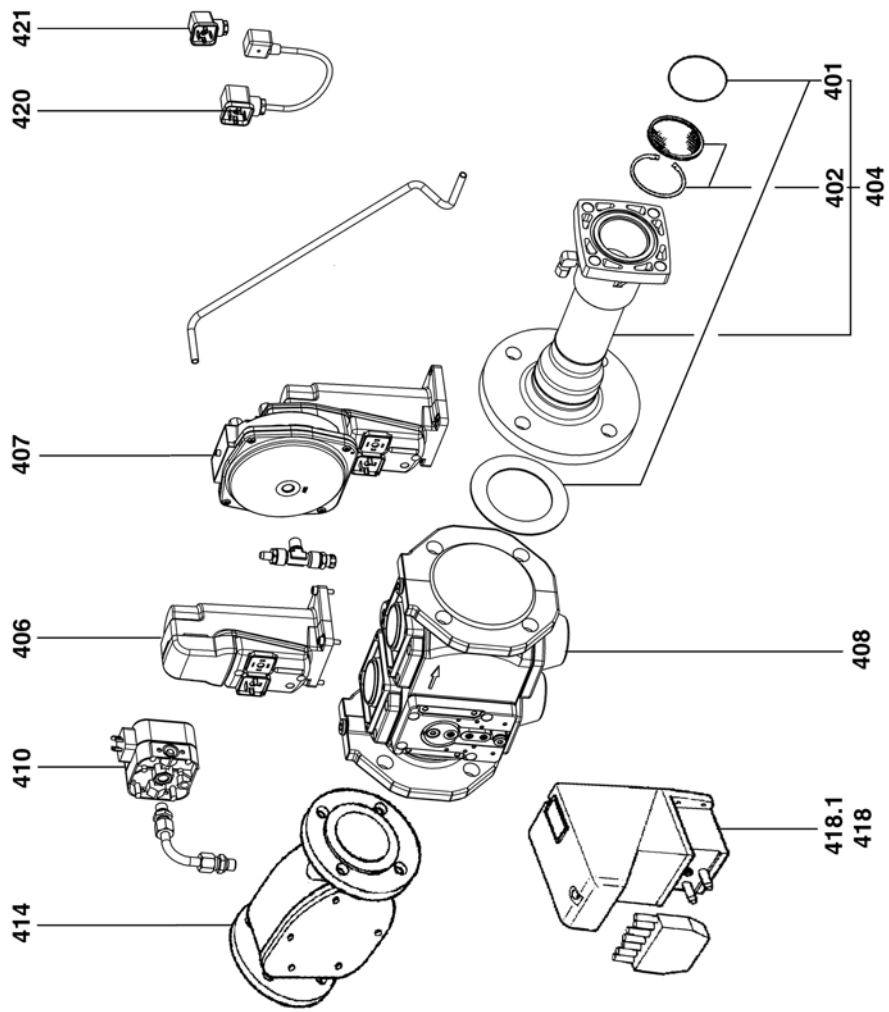

Pos	Désignation	Denominazione	Designación	Description	Bezeichnung	Название	Art. Nr.
401	Kit Joints 1 Rp2 2 DN65 3 DN80	Kit guarnizione	Kit junta	Seal set	Dichtung Set	Уплотнение - комплект	13 011 733 13 013 781 13 013 782
402	Circlips + stabilisateur Ø 60	Fermaglio + stabilizzatore	Grupillas + estabilizador	Circlips + Stabilizer	Sicherungsring + Stabilisator	Предохранительное кольцо + стабилизатор	13 011 367
404	Collecteur monté 1 Rp 2 2 DN65 3 DN80	Collettore	Colector	Gas tube cpl.	Anschlußflansch BG	Фланец/газовая труба	13 013 783 13 013 784 13 013 785
406	Vanne de sécurité SKP 15.000E2	Valvola di sicurezza	Válvula de seguridad	Safety valve	Sicherheitsventil	Предохранительный клапан	13 020 951
407	Régulateur SKP 75.003E2	Regolatore	Regulador	Governor	Stellant.	Сервопривод	13 020 950
408	Vanne principale 1 VGD 20.507 Rp2 2 VGD 40 065 DN65 3 VGD 40.080 DN80	Valvola principale	Válvula principal	Principal valve	Hauptventil	Главный клапан	13 013 777 13 011 847 13 013 786
410	Pressostat GW 50 A4	Pressostato	Pressostato	Press. cont. device	Druckwächter	Реле давления	13 016 462
414	Filtre extérieur 1 Rp2 2 DN65 3 DN80	Filtro esterno	Filtro exterior	External filter	Gasfilter	Наружный фильтр	13 009 700 13 009 703 13 013 787
414.1	Elément filtrant 1 Rp2 2 DN65 3 DN80	Elemento filtrante	Elemento filtrante	Strainer element	Gasfilter-Einsatz	Фильтрующий элемент	13 015 864 13 015 860 13 015 861
418	Contrôleur d'étanchéité VPS504 S01	Controllore di tenuta	Controlador de estanqueidad	Tightness control	Dichtprüfgerät	Орган контроля утечек	13 001 778
420	Câble de liaison			Link cable		Câble de liaison	13 020 958
421	Connecteur bridge AGA68			Bridge plug	Zwischenstecker	Connecteur bridge AGA68	13 022 511



Schémas électrique et hydraulique
Schemi elettrico e idraulico
Esquema eléctrico y hidráulico
Electric and hydraulic diagrams
Elektro- und Hydraulikschema
Электрические и гидравлические схемы

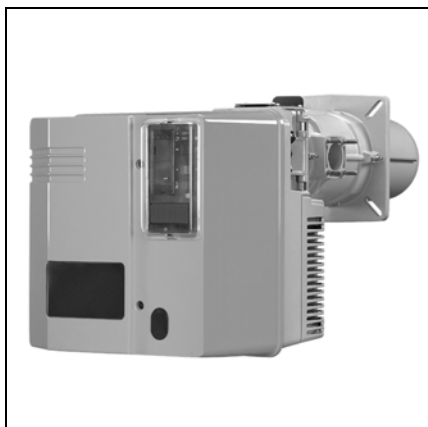

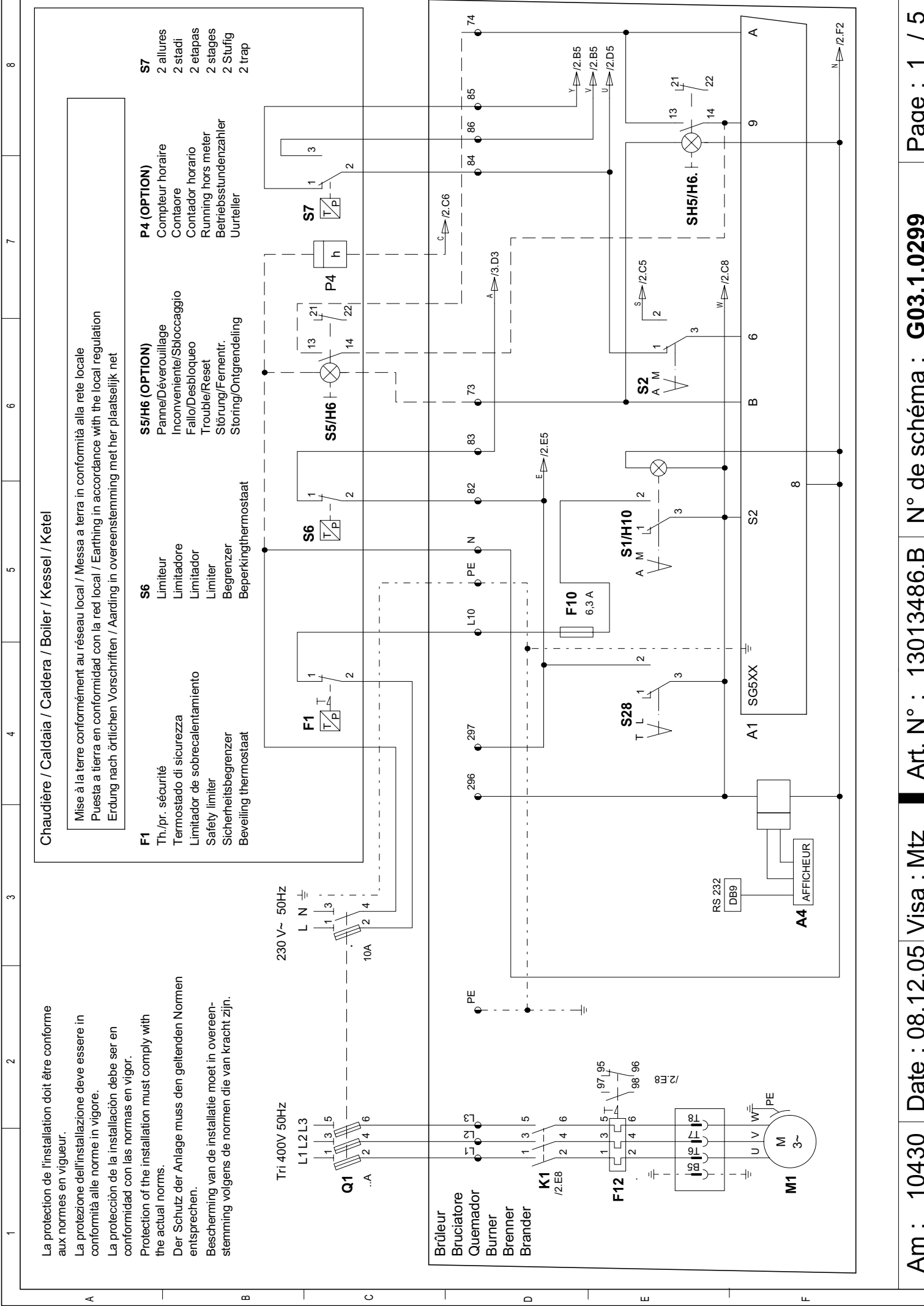

La protection de l'installation doit être conforme aux normes en vigueur.
 La protezione dell'installazione deve essere in conformità alle norme in vigore.
 La protección de la instalación debe ser en conformidad con las normas en vigor.
 Protection of the installation must comply with the actual norms.
 Der Schutz der Anlage muss den geltenden Normen entsprechen.
 Bescherming van de installatie moet in overeenstemming volgens de normen die van kracht zijn.

Mise à la terre conformément au réseau local / Messa a terra in conformità alla rete locale
 Puesta a tierra en conformidad con la red local / Earthing in accordance with the local regulation
 Erdung nach örtlichen Vorschriften / Aarding in overeenstemming met her plaatselijk net

- | | | | | | | | |
|-----------|---|------------|---|-----------------------|---|--------------------|--|
| F1 | Th./pr. sécurité
Termostado di sicurezza
Limitador de sobrecalentamiento
Safety limiter
Sicherheitsbegrenzer
Beveiliging thermostaat | S6 | Limiteur
Limitadore
Limitador
Limiter
Begrenzer
Beperkingthermostaat | S5/H6 (OPTION) | Panne/Déverouillage
Inconveniente/Sbloccaggio
Fallo/Desbloqueo
Trouble/Reset
Störung/Fermentr.
Storing/Ontgrendeling | S7 | 2 allures
2 stadi
2 etapas
2 steges
2 Stufig
2 trap |
| | | F10 | | S1/H10 | | P4 (OPTION) | Compteur horaire
Contaore
Contador horario
Running hors meter
Betriebsstundenzähler
Uurteller |

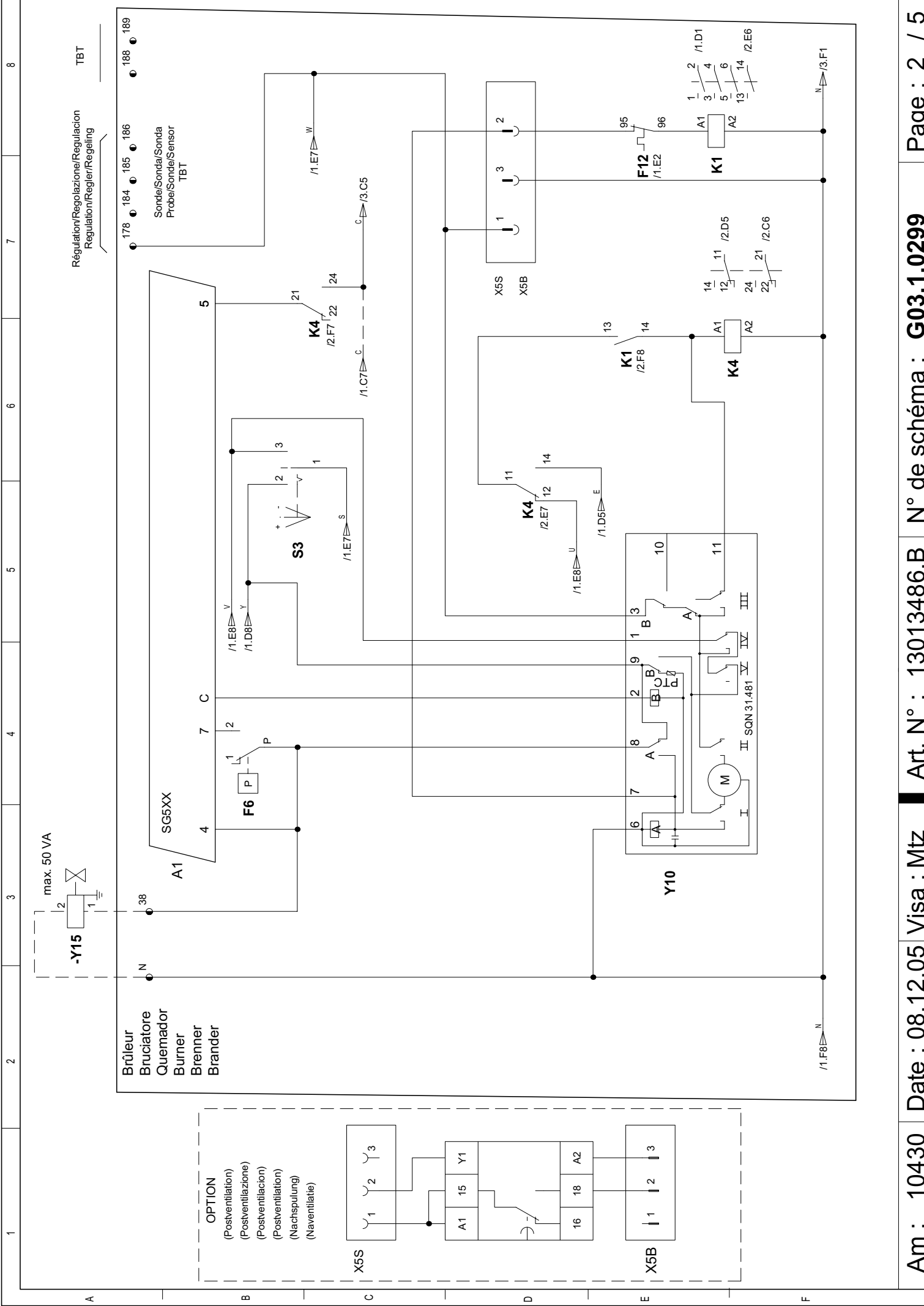

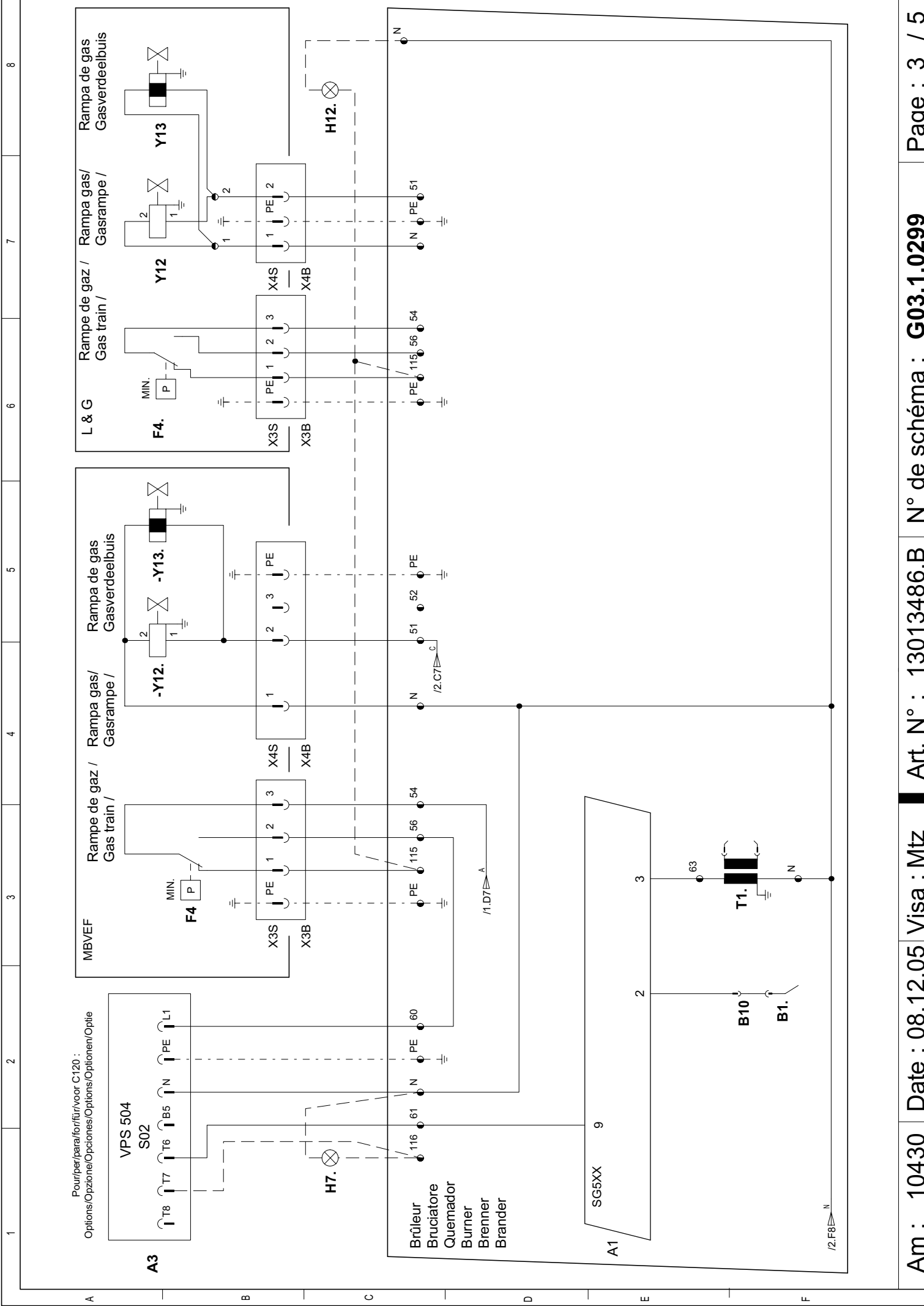

	1	2	3	4	5	6	7	8
A								
B								
C								
D								
E								
F								

"FR"

"IT"

"ES"

"GB"

"DE"

"NL"

	"FR"	"IT"	"ES"	"GB"	"DE"	"NL"
A1	Coffret de contrôle	Programmatore di comando	Caja de mando y seguridad	Control and safety unit	Feuerungsautomat	Bedienings en veiligheidskoffer
A3	Contrôle d'étanchéité	Controllo della tenuta	Control de estanqueidad	Tightness controller	Dichtheitskontrollgerät	Afdichtingscontrole
A4	Afficheur	Visualizzatore	Pantalla de visualización	Display	Anzeigevorrichtung	Uitlezing
B1	Electrode d'ionisation	Elettrodo d'ionizzazione	Electrodo de ionizacion	Ionisation electrode	Ionisationselectrode	Ionisatie-elektrode
B10	Pont de mesure	Ponte di misura	Puente de medicion	Current bridge	Messbruecke	Meetbrug
F4	Manostat gaz min.	Pressostato gas	Presostato de gas	Min gas pressure switch	Gasdruck wächter min.	Gaspressostaat
F6	Manostat d'air	Pressostato aria	Presostato de aire	Air pressure switch	Luftdruck wächter	Luchtpressostaat
F10	Fusible	Fusibile	Fusible	Control fuse	Sicherung	Zekering
F12	Protection thermique M1	Protezione termica M1	Proteccion termica M1	Thermal protection M1	Wärmeschutz M1	Thermische bescherming M1
H7	Défaut étanchéité	Difetto di tenuta	Fallo de estanqueidad	Tightness fault	Dichtheitsmangel	Afdichtingsfout
H12	Manque de gaz	Mancaanza del gas	Ausencia de gas	Gas lack	Gasmangel	Gasgebrek
K..	Contacteur/relais	Contactore/rele	Contacto/rele	Contactior/relay	Schalter/Relais	Contactoor/relais
M1	Moteur du brûleur	Motore del bruciatore	Motor del quemador	Burner motor	Brennmotor	Brandermotor
S1/H10	Marche/arrêt	Acceso/spento	Marcha/Parada	On/off	Ein/Aus	Aan/Uit
S2	Inter. man.-auto.	Interr. man/auto	Interrupor manual/auto	Man./auto. response	Wahlschalter man.-autom.	Schakelaar man./auto
S3	Inter. +/-	Interr. +/-	Interrupor +/-	+/- switch	Schalter +/-	Schak. +/-
SH5/H6	Déverouillage	Sbloccaggio	Desbloqueo	Reset	Fementr.	Ontgrendeling
S28	Inter. Télécommande/local	Interr. Telecomando/locale	Inter. telemando/local	Local/remote control inter.	Inter-Fernsteuerung / Ort	Schakelaar Afstandsbediening/lokaal
T1	Transfo.	Trasformatore	Transformador de encendido	Ignition transfo.	Zündtrafo.	Ontstekings- transformator
Y10	Servomoteur	Servomotor	Servomotor	Damper motor	Stellantrieb	Servomotor
Y12	Vanne gaz de sécurité	Valvola sicurezza gas	Valvula de seguridad de gas	Safety gas valve	Sicherheitsgasventil	Veiligheidsafsluiter gas
Y13	Vanne gaz principale	Valvola principale gas	Valvula de gas principal	Gas valve burner side	Gasventilbrennerseitig	Hoofdafsluiter gas
Y15	Vanne de protection	Valvola di protezione	Valvula de proteccion	Protection valve	Schutzventil	Beschermingsafsluiter
286/297	M/A par télécommande	Acceso/spento con telecomando	Marcha/Parada mediante telemando	ON/OFF by remote control	Ein/Aus ferngesteuert	Aan/Uit met afstandsbesturing

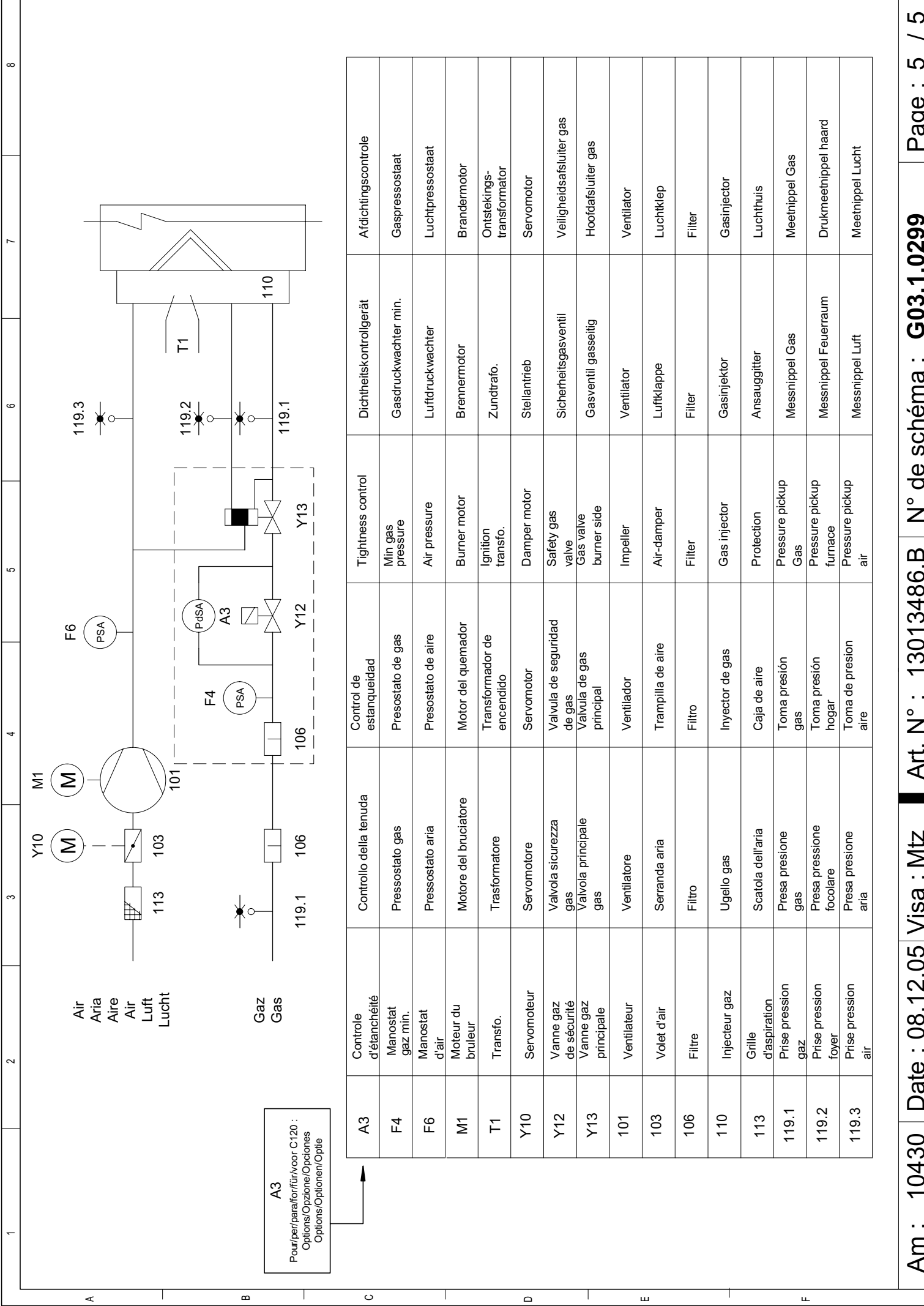

1 2 3 4 5 6 7 8

Air
Aria
Aire
Air
Luft
Lucht

Gaz
Gas

A3
Pour/per/para/for/für/voor C120 :
Options/Opciones/Opciones
Options/Optionen/Optie

A3	Controlle d'étanchéité	Controllo della tenuta	Control de estanqueidad	Tightness control	Dichtheitskontrollgerät	Afdichtingscontrole
F4	Manostat gaz min.	Pressostato gas	Presostato de gas	Min gas pressure	Gasdruckwächter min.	Gaspressostaat
F6	Manostat d'air	Pressostato aria	Presostato de aire	Air pressure	Luftdruckwächter	Luchtpressostaat
M1	Moteur du bruleur	Motore del bruciatore	Motor del quemador	Burner motor	Brennermotor	Brandemotor
T1	Transfo.	Trasformatore	Transformador de encendido	Ignition transfo.	Zundtrafo.	Ontstekings-transformator
Y10	Servomoteur	Servomotore	Servomotor	Damper motor	Stellantrieb	Servomotor
Y12	Vanne gaz de sécurité	Valvola sicurezza gas	Valvula de seguridad de gas	Safety gas valve	Sicherheitsgasventil	Veiligheidsafsluiter gas
Y13	Vanne gaz principale	Valvola principale gas	Valvula de gas principal	Gas valve burner side	Gasventil gaseitig	Hoofdafsluiter gas
101	Ventilateur	Ventilatore	Ventilador	Impeller	Ventilator	Ventilator
103	Volet d'air	Serranda aria	Trampilla de aire	Air-damper	Luftklappe	Luchtklep
106	Filtre	Filtro	Filtro	Filter	Filter	Filter
110	Injecteur gaz	Ugello gas	Injector de gas	Gas injector	Gasinjector	Gasinjector
113	Grille d'aspiration	Scatola dell'aria	Caja de aire	Protection	Ansauggitter	Luchthuis
119.1	Prise pression gaz	Presa pressione gas	Toma presión gas	Pressure pickup Gas	Messnippel Gas	Meetnippel Gas
119.2	Prise pression foyer	Presa pressione focolare	Toma presión hogar	Pressure pickup furnace	Messnippel Feuerraum	Drukmeetnippel haard
119.3	Prise pression air	Presa pressione aria	Toma de presión aire	Pressure pickup air	Messnippel Luft	Meetnippel Lucht





CUENOD
18 rue des Buchillons
F – 74100 Annemasse