

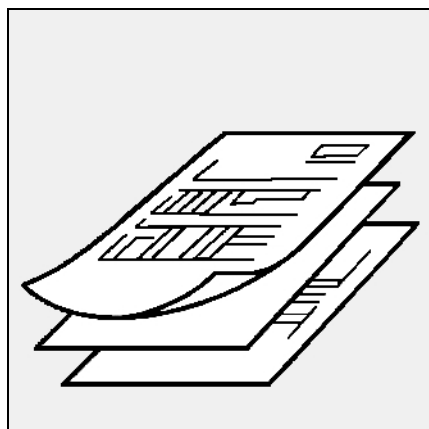

## C24, C30 GX507/8



**Données techniques**  
**Brûleurs gaz**..... 3-7

FR

**Dati tecnici**  
**Bruciatori di gas** ..... 3-7

IT



**Datos técnicos**  
**Quemadores de gas** ..... 3-7

ES

**Technical data**  
**Gas burners** ..... 3-7

EN

**Technische Daten**  
**Gasgebläsebrenner** ..... 3-7

DE

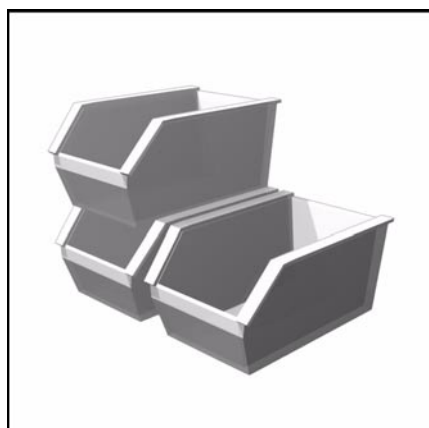

**Технические характеристики**  
**Газовые горелки** ..... 3-7

RU

**Pièces de rechange**  
**Pezzi di ricambio**  
**Piezas de recambio**  
**Spare parts list**  
**Ersatzteilliste**  
**Запчасти** ..... 9-14



**Schémas électrique et hydraulique**  
**Schemi elettrico e idraulico**  
**Esquema eléctrico y hidráulico**  
**Electric and hydraulic diagrams**  
**Elektro- und Hydraulikschema**  
**Электрические и гидравлические схемы**15-18





# Principaux composants / Caratteristiche d'utilisation

## Componenti principali / Caratteristiche d'impiego

### Componentes principales / Características de utilización

#### Main components / Characteristics of use

#### Wichtigste Komponenten / Betriebsdaten

#### Основные комплектующие / Рабочие характеристики

#### Principaux composants:

- Coffret de commande et sécurité: SG 513
- Détecteur de flamme: Sonde d'ionisation
- Moteur de ventilation: monophasé 230V, 50Hz, 2900tr/min 130W, cond. 6µF / 430V
- Turbine de ventilation : Ø160x52
- Transformateur d'allumage: EBI 1 x 11kV
- Commande volet d'air : Servomoteur: STA 19
- Manostat d'air : LGW 3 A2

#### Caractéristiques d'utilisation

- Température ambiante :
- d'utilisation : -5 ... 40°C
  - de stockage : - 20 ... 70°C
- Tension / Fréquence:
- 230 VAC -15 ... +10% - 50Hz<sup>±1%</sup> monophasé
- Degré de protection : IP 21



Dans le cas d'une alimentation électrique sans neutre à la terre, installer un transformateur d'isolement de 2,0 A/400 VA.

#### Componenti principali

- Programmatore di comando e di sicurezza: SG 513
- Rilevatore di fiamma: Sonda di ionizzazione
- Motore del ventilatore monophasé 230V, 50Hz 2900 giri/min 130W, condens. 6µF / 440V
- Turbina del ventilatore: Ø160x52
- Trasformatore d'accensione: EBI 1 x 11kV
- Comando serranda aria: Servomotore: STA 19
- Manostato aria: LGW 3 A2

#### Caratteristiche d'impiego

- Temperatura ambiente :
- d'utilizzazione : -5 ...40° C
  - di stoccaggio : -20 ...70° C
- Tensione / Frequenza :
- 230 VAC -15...+10% - 50 Hz<sup>±1%</sup> monofase
- Grado di protezione : IP 21



In caso di alimentazione elettrica senza neutro collegato a terra, installare un trasformatore d'isolamento di 2,0 A/400 VA.

#### Principales componentes

- Cajetín de control y seguridad: SG 513
- Detector de llama: Sonda de ionización
- Motor de ventilación: monofásico 230V, 50Hz, 2900 t/min 130W, cond. 6µF / 430V
- Turbina de ventilación: Ø160x52
- Transformador de encendido: EBI 1 x 11kV
- Control de la trampilla de aire: Servomotor: STA 19
- Manóstató de aire: LGW 3 A2

#### Características de utilización

- Temperatura ambiente :
- de utilización : - 5 ...40° C
  - de almacenamiento : - 20 ...70° C
- Tensión eléctrica / Frecuencia :
- 230 VAC -15...+10% - 50 Hz<sup>±1%</sup> monofásico
- Grado de protección : IP 21



En caso de alimentación eléctrica sin neutro a tierra instalar un transformador de aislamiento de 2,0 A/400 VA.

#### Main components

- Control and safety unit SG 513
- Flame detector : ionisation probe
- Fan motor : single-phase 230V, 50Hz, 2900 rpm 130W, capacitor 6µF / 430V
- Ventilation turbine Ø160 x 52
- Firing transformer EBI 1 x 11kV
- Air flap control : Servomotor : STA 19
- Air pressure switch : LGW 3 A2

#### Characteristics of use

- Ambient temperature :
- for use : - 5... 40° C
  - for storage : - 20... 70° C
- Voltage / Frequency :
- 230 VAC -15...+10% - 50 Hz<sup>±1%</sup> single-phase
- Protection level : IP 21



With an electrical power supply without an earthed neutral, install a 2.0 A/400 VA isolation transformer.

#### Wichtigste Komponenten:

- Feuerungsautomat SG 513
- Flammenüberwachung: Ionisationssonde
- Gebläsemotor: einphasig 230V, 50Hz, 2900 min<sup>-1</sup> 130 W, Kondensator: 6 µF / 430 V
- Lüfterrad: Ø160 x 52
- Zündtrafo: EBI 1 x 11 kV
- Luftklappensteuerung: Stellantrieb: STA 19
- Luftdruckwächter: LGW3 A2

#### Betriebsdaten

- Umgebungstemperatur :
- Betriebstemperatur : -5...40°C
  - Lagerungstemperatur : -20...70°C
- Spannung/Frequenz :
- 230 VAC -15...+10% - 50 Hz<sup>±1%</sup> einphasig
- Schutzart : IP 21



Bei einer Stromversorgung ohne geerdeten Nullleiter einen Isoliertrafo mit 2,0 A/400 VA installieren.

#### Основные комплектующие:

- Блок управления и безопасности SG 513
- Детектор пламени: Ионизационный зонд
- Двигательвоздуходувки: однофазный 230 В, 50 Гц, 2900 мин<sup>-1</sup>, 130 Вт конденсатор 6 мкФ/430 В
- Турбина вентилятора: Ø160x52
- Трансформатор розжига: EBI 1 x 11 kV
- Привод воздушной заслонки: серводвигатель: STA 19
- Воздушный регулятор: LGW3 A2

#### Рабочие характеристики

- Температура окружающего воздуха
- при эксплуатации: -5 ... 40 °C
  - при хранении: - 20 ... 70 °C
- Напряжение/Частота:
- 230 В переменного тока -15 ...+10 % - 50 Гц<sup>±1%</sup> однофазный
- Уровень электрозащиты: IP 21



При использовании электропитания без заземленной нейтрали установите изолирующий трансформатор 2,0 A/400 VA.

**Courbes de puissance**  
**Curve di potenza**  
**Diagramas de potencia**  
**Power graphs**  
**Arbeitsfelder**  
**Рабочие кривые**

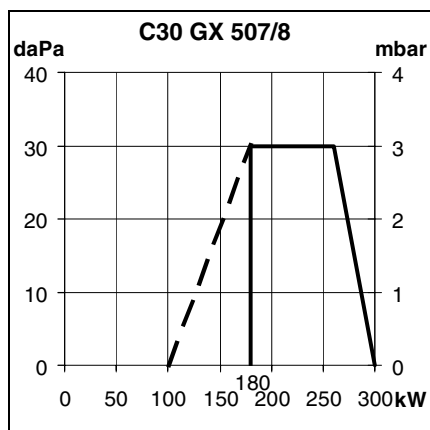
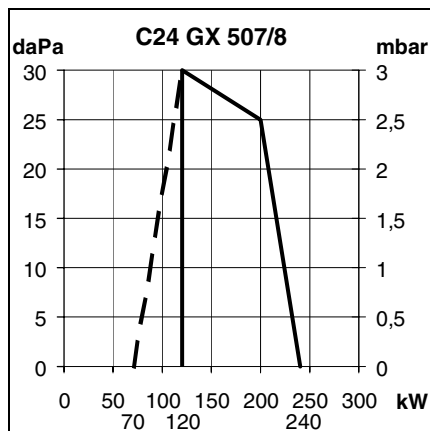

Puissance kW Potenza kW Potencia kW Power kW Leistung kW Мощность кВт	C24 GX 507/8		C30 GX 5807/8	
	min мин.	max макс.	min мин.	max макс.
Brûleur (kW)	120	240	180	300
Min. allumage (kW)	70	—	100	—
Générateur (kW)	110	221	166	276
Débit nominal réel de gaz à 15°C et 10.13 mbar				
Naturel groupe H Hi =9,45	m³/h (kWh/m³)	12,7 25,4	19,0 31,7	31,7
Naturel groupe L Hi =8,13	m³/h (kWh/m³)	14,8 29,5	22,1 36,9	36,9
Propane P Hi =24,44	m³/h (kWh/m³)	4,9 9,8	7,4 12,3	12,3
Masse volumique kg/m³ = 1,98				
Bruciatore (kW)	120	240	180	300
Min. accensione (kW)	70	—	100	—
Generatore (kW)	110	221	166	276
Portata nominale eff. di gas a 15°C e 10.13 mbar				
Naturale gruppo H Hi =9,45	m³/h (kWh/m³)	12,7 25,4	19,0 31,7	31,7
Naturale gruppo H Hi =8,13	m³/h (kWh/m³)	14,8 29,5	22,1 36,9	36,9
Propano P Hi =24,44	m³/h (kWh/m³)	4,9 9,8	7,4 12,3	12,3
Massa volumica kg/m³ = 1,98				
Quemador (kW)	120	240	180	300
Min. encendido (kW)	70	—	100	—
Generador (kW)	110	221	166	276
Caudal nominal real de gas a 15°C y 10.13 mbar				
Natural grupo H Hi =9,45	m³/h (kWh/m³)	12,7 25,4	19,0 31,7	31,7
Natural grupo L Hi =8,13	m³/h (kWh/m³)	14,8 29,5	22,1 36,9	36,9
Propano P Hi =24,44	m³/h (kWh/m³)	4,9 9,8	7,4 12,3	12,3
Densidad kg/m³ = 1,98				
Burner (kW)	120	240	180	300
Min. ignition (kW)	70	—	100	—
Generator (kW)	110	221	166	276
Actual gas flow rate at 15°C and 10.13 mbar				
Natural group H Hi =9,45	m³/h (kWh/m³)	12,7 25,4	19,0 31,7	31,7
Natural group L Hi =8,13	m³/h (kWh/m³)	14,8 29,5	22,1 36,9	36,9
Propane P Hi =24,44	m³/h (kWh/m³)	4,9 9,8	7,4 12,3	12,3
Voluminal mass kg/m³ = 1,98				
Brenner (kW)	120	240	180	300
Min. Zündleistung (kW)	70	—	100	—
Kessel (kW)	110	221	166	276
Effektiver Gasdurchsatz bei 15°C und 10.13 mbar				
Erdgas Gruppe H Hi =9,45	m³/h (kWh/m³)	12,7 25,4	19,0 31,7	31,7
Erdgas Gruppe L Hi =8,13	m³/h (kWh/m³)	14,8 29,5	22,1 36,9	36,9
Flüssiggas P Hi =24,44	m³/h (kWh/m³)	4,9 9,8	7,4 12,3	12,3
Dichte kg/m³ = 1,98				
Горелка (кВт)	120	240	180	300
Мин. Мощность розжига (кВт)	70	—	100	—
Котел (кВт)	110	221	166	276
Эффект. расход газа при 15°C и 10.13 мбар				
Природный газ группы H Hi =9,45	m³/ч (кВтч/м³)	12,7 25,4	19,0 31,7	31,7
Природный газ группы L Hi =8,13	m³/ч (кВтч/м³)	14,8 29,5	22,1 36,9	36,9
Сжиженный газ П Hi =24,44	m³/ч (кВтч/м³)	4,9 9,8	7,4 12,3	12,3
Плотность кг/м³ = 1,98				

**Composition de la rampe gaz**  
**Composizione della rampa gas**  
**Composición de la rampa de gas**  
**Gas manifold composition**  
**Zusammensetzung der Gasarmatur**  
**Состав газовой рампы**

Brûleur Bruciatore Queimador Burner Brenner Горелка	Gaz Gas Gas Gas Gas Газ	P gaz P Gas P Gas P Gas P Gas P Газ	P max P макс.	Vanne Valvola Válvula Valve Ventil Клапан		Contrôleur étanchéité Controllore tenuta Control. estanqueidad Leakage test unit Dichtheitskontroll Контроллер герметичности	Filtre Filtro Filtro Filter Filter Фильтр			Manostat Manostato Manóstato Press. Switch Druckwächter Регулятор			
				MB VEF...	Ø bride Ø flangia Ø brida Ø flange Ø Flansch Ø фланца Rp		VPS...	Intégré Incorp. Integrado Integrated Interner внутр. FI	extérieur externo external externer наружн. Rp		poche tasca bolsa pocket Taschen карман. FP	GW....	
C24 GX 507	G20	20	240	412	1,1/4		FI			150 A5			
		300		407	3/4			1					
	G25	25		412	1,1/4		FI						
		300		407	3/4			1					
C24 GX 508	G31	37		300	407		3/4					1	
		148											
C30 GX 507	G20	20		300	412		1,1/4				FI		
		300			407		3/4					1	
	G25	25	412		1,1/4	FI							
		300	407		3/4		1						
C30 GX 508	G31	37	300		407	3/4				1			
		148											

Type Tipo Tipo Type Art Тип	Groupe Gruppo Grupo Group Gruppe Группа	Pression de distribution Pressione di distribuzione Presión de distribución Distribution pressure Eingangsdruck Давление на входе			Hi à 0°C et 1013 mbar Hi a 0°C e 1013 mbar Hi à 0° C y 1013 mbar Hi at 0°C and 1013 mbar Hi bei 0°C und 1013mbar Hi при 0°C и 1013 мбар		Gaz Gas Gas Gas Gas Газ
		Pn mbar мбар	Pmin mbar мбар	Pmax mbar мбар	min (kWh/m³) (кВтч/м³)	max (kWh/m³) (кВтч/м³)	
Gaz H Gas H Газ H	2H	20 300	17 240	25 360	9,5	11,5	G20
Gaz L Gas L Газ L	2L	25 300	20 240	30 360	8,5	9,5	G25
Gaz P Gas P Газ P	3P	37 148	25 120	45 180	24,5	26,5	G31

**Encombrement Dimensions  
Dimensioni d'ingombro  
Dimensiones Medidas  
Space requirements and dimensions  
Maßbild und Abmessungen  
Занимаемый объем Размеры**

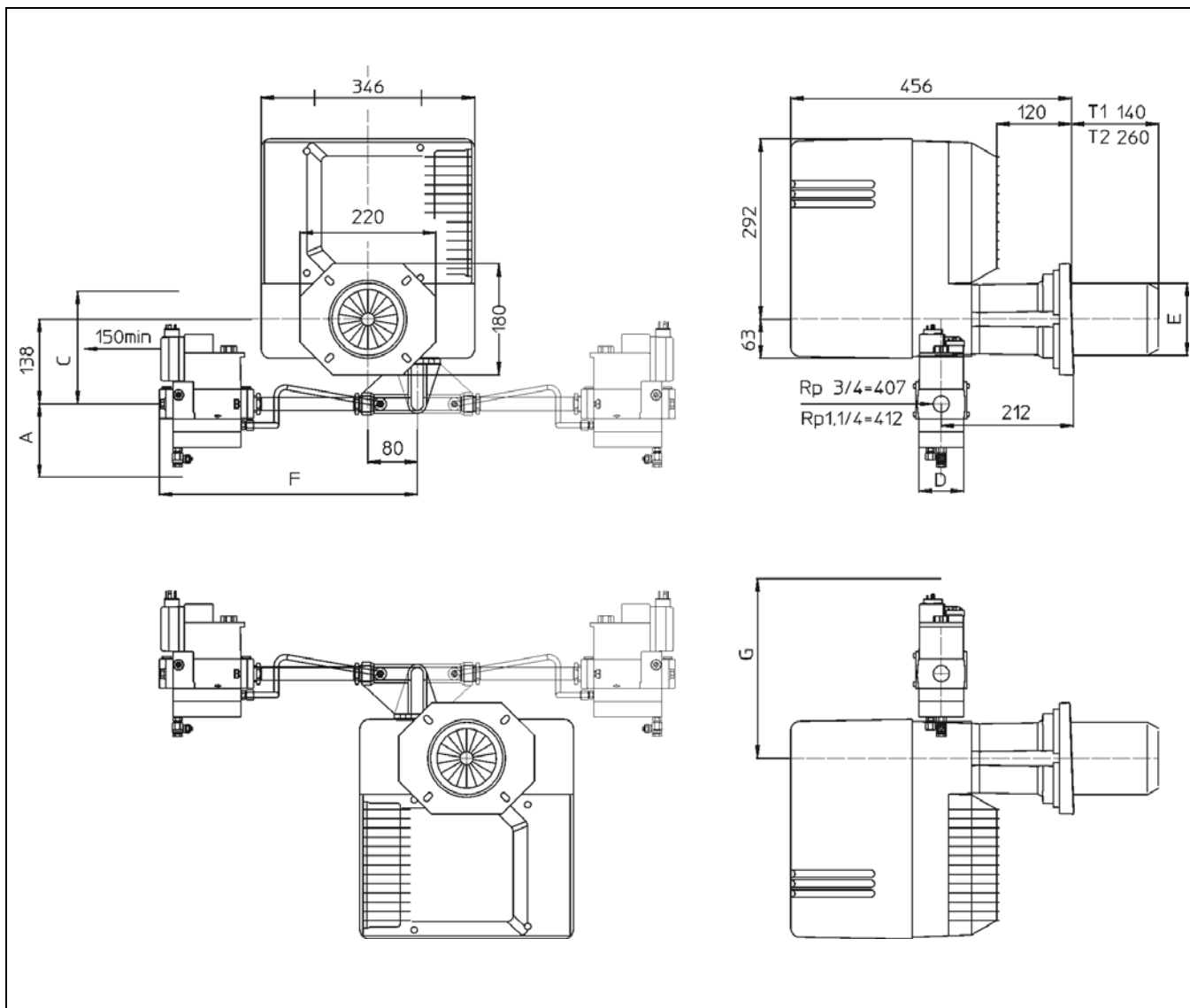

	A	C	D	E	F	G
p37-148-300	102	180	73	124	419	317
p20-25	100	169	96		452	320

**Pour l'implantation volute en bas :**  
lire les informations complémentaires au paragraphe "Installation" montage du brûleur.

**Per l'installazione con la voluta verso il basso:**  
leggere le informazioni complementari al paragrafo "Installazione", montaggio del bruciatore.

**Para colocar la voluta hacia abajo :**  
leer las informaciones complementarias en el párrafo "Instalación" montaje del quemador.

**For setting-up with the spiral at bottom :**  
read the additional information in the "Assembly" paragraph of the burner installation instructions.

**Für den Einbau mit nach unten gerichtetem Lüfterrad :**  
die ergänzenden Informationen des Kapitels " Installation " Montage des Brenners beachten.

**При установке спирали снизу:**  
см. дополнительную информацию в разделе "Установка" Монтаж горелки.

# Encombremet Dimensions

## Dimensioni d'ingombro

## Dimensiones Medidas

## Space requirements and dimensions

## Maßbild und Abmessungen

## Занимаемый объем Размеры

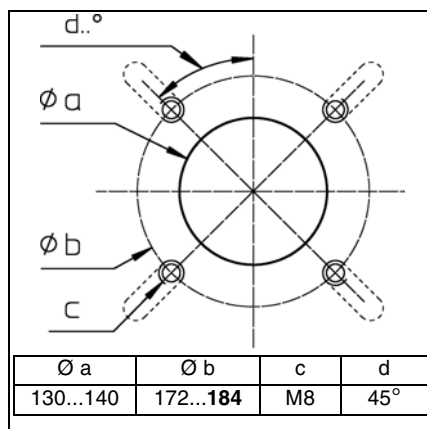

### Encombremet et dimensions

Respecter une distance libre minimum de 0,6 mètre de chaque côté du brûleur pour permettre les opérations de maintenance.

### Ventilation chaufferie

Le volume d'air neuf requis est de 1,2 m³/kWh produit au brûleur.

### Rampe gaz

S'implante uniquement à l'horizontale à **droite** ou à gauche.

### Dimensioni d'ingombro

Lasciare uno spazio libero minimo di 0,6 metri su ogni lato del bruciatore per consentire le operazioni di manutenzione.

### Ventilazione locale caldaia

La portata dell'aria di ricambio del locale deve essere almeno di 1,2 m³/kWh bruciatore.

### Rampa gas

Deve essere installata unicamente in orizzontale a **destra** o a sinistra.

### Dimensiones y Medidas

Respetar una distancia libre mínima de 0,6 metros a ambos lados del quemador para permitir las operaciones de mantenimiento.

### Ventilación calentador

El volumen de aire nuevo requerido es de 1,2 m³/kWh producido en el quemador.

### Rampa de gas

Sólo se coloca en horizontal a la **derecha** o a la izquierda

### Space requirements and dimensions

Leave a space of at least 0.6 metres on each side of the burner for maintenance purposes.

### Boiler-house ventilation

Volume of fresh air required is 1.2 m³/kWh produced at the burner.

### Gas manifold

Can only be installed horizontally, on the **right** or on the left.

### Maßbild und Abmessungen

Für Servicearbeiten ist ein freier Abstand von min. 0,6 m auf jeder Seite des Brenners sicherzustellen.

### Heizraumbelüftung

Die nötige Frischluftzufuhr beträgt 1,2 m³/kWh am Brenner.

### Gasarmaturgruppe

Montage waagrecht **rechts** oder links möglich

### Занимаемый объем и размеры

Обеспечьте свободное пространство минимум 0,6 м с каждой стороны горелки для осуществления работ по ее обслуживанию.

### Вентиляция котла

Требуемый объем приточного воздуха для производительности горелки 1,2 м³/кВтч.

### Газовая рампа

Устанавливается только в горизонтальном положении **с правой** или левой стороны.







**Pièces de rechange**  
**Pezzi di ricambio**  
**Piezas de recambio**  
**Spare parts list**  
**Ersatzteilliste**  
**Запчасти**

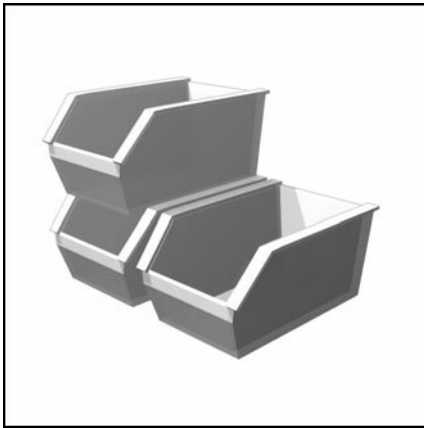

**C24, C30 GX507/8**



C 24 GX 507/8T1 p 20	13 005 060
C 24 GX 507/8T2 p 20	13 005 061
C 24 GX 507/8T1 p 300	13 005 062
C 24 GX 507/8T2 p 300	13 005 063
C 30 GX 507/8T1 p 20	13 005 068
C 30 GX 507/8T2 p 20	13 005 069
C 30 GX 507/8T1 p 300	13 005 070
C 30 GX 507/8T2 p 300	13 005 071



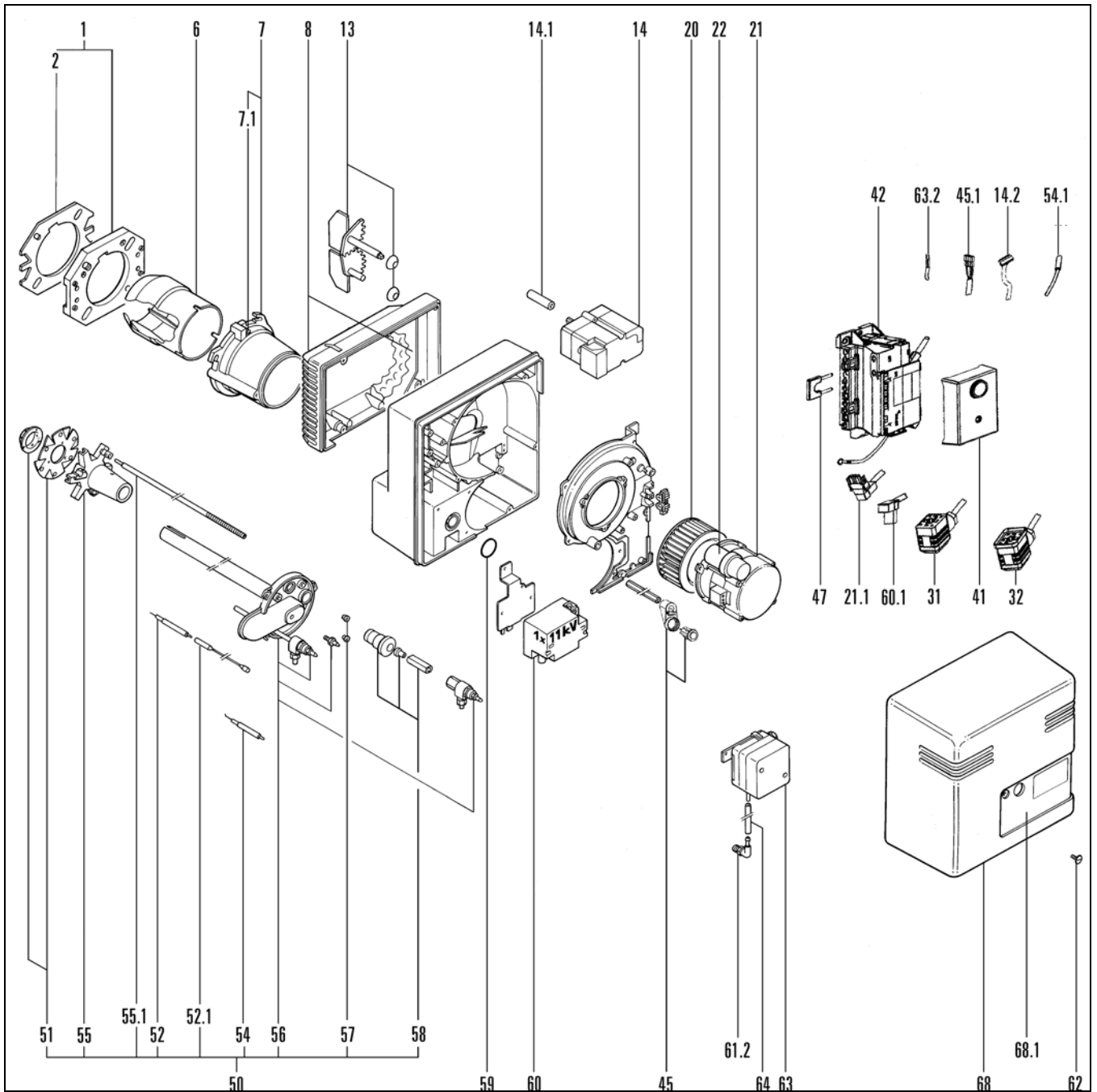

Pos.	Désignation	Denominazione	Designación	Description	Bezeichnung	Назначение	Art. Nr.
01	Accessoires chaudière	Accessori caldaia	Accesorios caldera	Boiler accessories	Anschlussflansch BG.	Дополнительное оборудование для котла	13 015 504
02	Joint/chaudière Ø127	Guarnizione Ø127	Junta Ø127	Boiler front seal Ø127	Isolierflansch Ø127	Прокладка передней панели Ø127	13 016 233
06	Embout	Imbuto	Cañon	Blast tube	Brennerrohr	Трубка датчика давления камеры сгорания	13 015 903 13 015 905
	C24 Ø100/90/124/115 x182 T1 x302 T2	C24 Ø100/90/124/115 x182 T1 x302 T2	C24 Ø100/90/124/115 x182 T1 x302 T2	C24 Ø100/90/124/115 x182 T1 x302 T2	C24 Ø100/90/124/115 x182 T1 x302 T2	C24 Ø100/90/124/115 x182 T1 x302 T2	
	C30 Ø100/90/124/115 x182 T1 x302 T2	C30 Ø100/90/124/115 x182 T1 x302 T2	C30 Ø100/90/124/115 x182 T1 x302 T2	C30 Ø100/90/124/115 x182 T1 x302 T2	C30 Ø100/90/124/115 x182 T1 x302 T2	C30 Ø100/90/124/115 x182 T1 x302 T2	13 015 906 13 015 904
07	Tête de fixation Ø115	Testa del bruciatore Ø115		Fixation head Ø115	Brennerrohraufnahme Ø115	Головка для фиксации жаровой трубы Ø115	
07.1	Vis/embout 3x	Vite/imbuto 3x	Tornillo/Cañon 3x	Screw/blast tube 3x	Schrauben-Set 3x	Комплект винтов 3x	13 016 777
08	Boîte à air éq.	Scatola d'aria completa	Caja de aire completa	Air damper cover cpl.	Luftkasten BG	Воздушная коробка BG	
13	Volet d'air	Serranda aria	Trampilla de aire	Air flap	Luftklappen BG	Воздушная заслонка	13 016 784
14	Servomoteur STA 19	Servomotore STA 19	Servomotor STA 19	Servomotor STA 19	Stellantrieb STA 19	Серводвигатель STA 19	13 016 568
14.1	Accouplement/ servomoteur	Accoppiamento/ servomotore	Acoplamiento/ servomotor	Coupling/servomotor	Kupplung/Stellantrieb	Сцепление / серводвигатель	13 015 533
14.2	Prise 9P.+ câble/ servomoteur	Prisa 9P.+ cavo / servo.	Toma 9P.+cable/ servomotor	Plug+cable/servomotor	Kabel m. Stecker 9P./Stell.	Разъем 9-полюсный + кабель/серводвигатель	13 020 215
20	Turbine Ø160X52	Ventilatore Ø160X52	Turbina Ø160X52	Air fan Ø160X52	Ventilatorrad Ø160X52	Турбина Ø160X52	13 016 706
21	Moteur 130W+condensat.	Motore 130W+ condensat.	Motore 130W + condensador	Motor 130W+capacitor	Motor 130W+Kondensator	Двигатель 130 Вт + конденсатор	13 016 368
21.1	Prise C. 3P.-câble/ moteur	Prisa 3P.+ cavo / motore	Toma C. 3P.-cable/motor	Plug+cable/motor	Kabel m. Stecker / Motor	Кабель со штекером 3-пол. / двигатель	13 015 630
22	Condensateur 6 µF,400V	Condensatore 6 µF,400V	Condensador 6 µF,400V	Capacitor 6 µF,400V	Kondensator 6 µF,400V 400V	Конденсатор 6 мкФ, 400В	13 015 273
31	Câble vanne gaz	Cavo valvola gas	Cable válvula gas	Plug+cable/gas valve without relay	Kabel Gasventil ohne Trennrelais	Кабель газового клапана	13 015 642
32	Câble manostat gaz	Cavo manostato gas	Cable manostato gas	Plug+cable/gas press. switch	Kabel Gasdruckwächter	Кабель газового регулятора	13 015 628
41	Coffret gaz SG 513	Programmatore gas SG 513	Cajetín gas SG 513	Control unit SG 513	Feuerungsautomat SG 513	Блок безопасности SG 513	13 015 700
42	Cassette de raccordement	Cassetta di collegamento	Casete de conexión	Elec. connection box	Anschlusskasten mit Relaissockel ohne Kabel	Кабельная коробка для подключения различных электроприборов к горелке	13 015 684
45	Kit bouton de réarmement	Kit pulsante de rearro	Kit torta/ cajetín de control	Set reset button	Taster / Entriegelung	Кнопка сброса	13 016 250
45.1	Câble bouton de réarmement	Cavo/pulsante di rearro	Cable torta/ cajetín de control	Plug+cable reset button	Kabel m. Stecker / Entriegelung	Кабель со штекером для кнопки сброса	13 015 613
47	Pont d'ionisation	Ponte di ionizzazione	Puente de ionización	Ionisation bridge	Verbindungsstecker	Ионизационный мост	13 016 455
50	Ligne gaz équipée T1 T2	Linea gas completa T1 T2	Linea gas T1 T2	Lance gas head T1 T2	Lanzengaskopf T1 T2	Газовая линия к соплу T1 T2	13 013 594 13 013 595



Pos.	Désignation	Denominazione	Designación	Description	Bezeichnung	Назначение	Art. Nr.
51	Déflecteur cpl. Ø89/30	Deflettore Ø89/30	Deflector Ø89/30	Turbulator Ø89/30	Turbulator + Gasdüse Ø89/30	Дефлектор в сборе Ø89/30	13 015 802
52	Electrode allu.	Elettrodo di accensione	Electrodo de encendido	Ignition electrode	Zündelektrode	Зажальный электрод	13 015 841
52.1	Câble allu. L625	Cavo di accensione L625	Cable de encendido L625	Ignition lead L625	Zündkabel L625	Кабель розжига L625	13 015 615
54	Sonde ionisation	Sonda di ionizzazione	Sonda de ionización	Ionisation probe	Ionisationssonde	ионизация	13 015 841
54.1	Câble sonde ioniz. L750	Cavo sonda ioniz. L750	Cable sonda de ionización L750	Ionisation cable L750	Ionisationskabel L750	Кабель ионизационного L750	13 015 636
55	Etoile répat. gaz Ø93	Ripartitore gas	Estrella gas	Star gas head	Sterngaskopf	Звездочка	13 010 023
55.1	Tube pression pF	Tubo pF	Tubos PL	Adjust linkage/pressure tube pF	Verstellspindel / Rohr pF	распределения газа	
	L470 T1	L470 T1	L470 T1	L470 T1	L470 T1	Регулировочный	13 010 024
	L590 T2	L590 T2	L590 T2	L590 T2	L590 T2	шпилька / трубка pF	13 010 033
56	Couvercle gaz + tube T1 T2	Coperchio gas + tubo T1 T2	Tapa gas/tubo T1 T2	Gas cover + tube T1 T2	Gasrohr T1 T2	Газовая труба	13 010 025
							13 010 026
57	Passe-fil/allum. Ø5/9 noir	Passa cavo /accens. Ø5/9 negro	Capuchón de goma/encend. Ø5/9 negro	Funnel/ignition Ø5/9 black	Tülle/Zünd. Tülle/ionis.	Насадка / розжиг Ш5/9 черный	13 016 394
							13 010 027
							13 010 027
58	Vernier équipé			Setting knob	Regulierknopf-Set	Регулировочная кнопка - комплект	13 016 854
59	Joint O'Ring	Anello di tenuta O'Ring	Junta O'Ring	O'Ring	O'Ring	Кольцевой уплотнитель	13 010 035
60	Transformateur allu. EBI 1x11kV	Trasformatore d'accens. EBI 1x11kV	Transformador EBI 1x11kV	Ignition transfo. EBI 1x11kV	Zündtrafo EBI 1x11kV	Трансформатор розжига EBI 1x11kV	13 016 668
60.1	Prise C.2P.-câble/transfo.	Prisa 2 poli + cavo trasf.	Toma C. 2P. + cavo/transf.	Cable+plug/ignition transfo.	Zündtrafo	Разъем C.2-полюсный + кабель/трансформатор.	13 012 226
61.2	Coude R1/8	Gornito	Codo	Lance	Messnippei-Winkel 1/8"	колено	13 013 352
62	Vis/capot	Vite fiss. coperchio	Tornillo/tapa	Screw/cover	Befestigungsschraube	Крепежный винт	13 016 776
63	Manostat LGW3 A2	Manostato aria LGW3 A2	Manóstato LGW3 A2	Press. switch LGW3 A2	Luftdruckwächter LGW3 A2	Реле давления воздуха LGW3 A2	13 016 344
63.2	Câble 3P./Manostat air	Cavo 3P. / manos. aria	Cable 3P. /manóstato aire	Cable/press. switch	Kabel 3P./Luftdruckwächter	Кабель воздушного регулятора	13 012 225
64	Tuyau PVC Ø4/6x220	PVC tubo Ø4/6x220	Tubo PVC Ø4/6x220	PVC tube Ø4/6x220	PVC Schlauch Ø4/6x220	Трубка из ПВХ Ø4/6x220	13 014 337
68	Capot orange	Coperchio arancio	Tapa naranja	Orange cover	Schutzhaube	Оранжевый кожух	13 015 661
68.1	Plaque frontale	Marchio frontale	Placa frontal	Standard front cover	Standard front cover	Лицевая панель	13 015 465

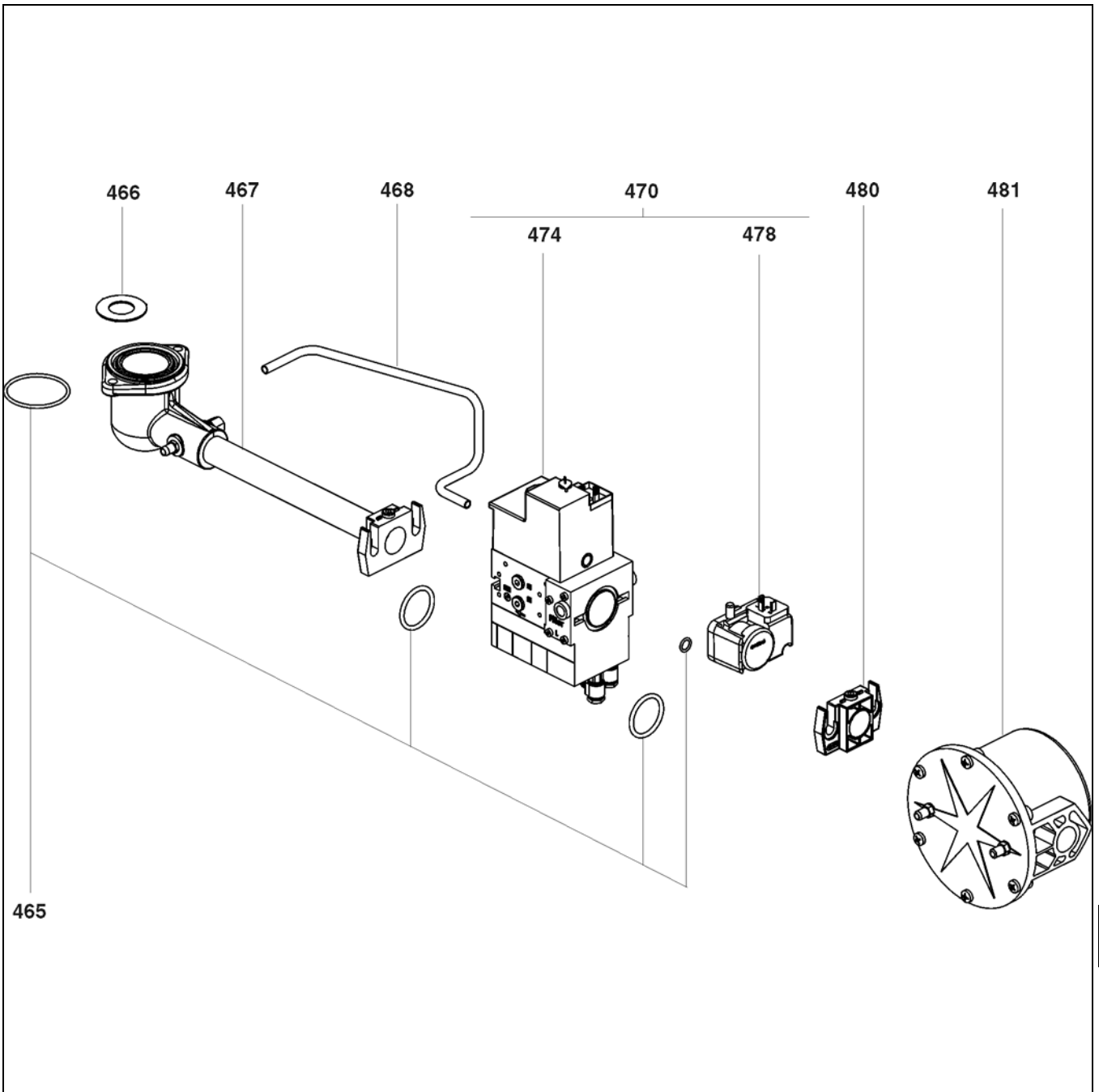

Pos	Désignation	Denominazione	Designación	Description	Bezeichnung	Назначение	Art. Nr.
400	Rampe gaz AGP C24/30 GX507/8p300 C24/30 GX507/8p20/25	Rampa gas AGP C24/30 GX507/8p300 C24/30 GX507/8p20/25	Rampa de gas AGP C24/30 GX507/8p300 C24/30 GX507/8p20/25	AGP gas valve assembly C24/30 GX507/8p300 C24/30 GX507/8p20/25	Gasarmatur-BG C24/30 GX507/8p300 C24/30 GX507/8p20/25	Газовая рампа AGP C24/30 GX507/8p300 C24/30 GX507/8p20/25	13 005 242 13 005 241
465	Kit Joint O'Ring MB VEF 407 MB VEF 412	Kit guarniz. O'ring MB VEF 407 MB VEF 412	Kit juntas O'Ring MB VEF 407 MB VEF 412	Set O'Ring MB VEF 407 MB VEF 412	O'Ring-set MB VEF 407 MB VEF 412	Кольцо круглого сечения / фланец MB VEF 407 MB VEF 412	13 018 125 13 018 127
467	Collecteur monté Rp 3/4 Rp 1"1/4	Collettore Rp 3/4 Rp 1"1/4	Colector Rp 3/4 Rp 1"1/4	Gas tube eq. Rp 3/4 Rp 1"1/4	Gasanschlussrohr Kpl. Rp 3/4 Rp 1"1/4	Коллектор в сборе Rp 3/4 Rp 1"1/4	13 012 042 13 012 043
468	Tube pression gaz	Tubeetto pressione gas	Tubo presión gas	Gas pressure tube	Druckabnahmerohr	Трубка для отбора давления	13 012 044 13 012 045
470	Vanne MB VEF 407 B01 S30 MB VEF 412 B01 S10	Valvola MB VEF 407 B01 S30 MB VEF 412 B01 S10	Válvula MB VEF 407 B01 S30 MB VEF 412 B01 S10	Gas valve MB VEF 407 B01 S30 MB VEF 412 B01 S10	Gasventil MB VEF 407 B01 S30 MB VEF 412 B01 S10	Задвижка основного обмена MB VEF 407 B01 S30 MB VEF 412 B01 S10	13 016 673 13 016 720
474	Bobine VS + VA1 1 407 1105 2 412 1205	Bobina VS + VA1	Bobina VS + VA1	Magnet coil VS + VA1	Magnetspule VS + VA1	Катушка VS + VA	13 015 555 13 015 560
477	Filtre tamis 1 412 2 407	Filtro 412 407	Filtro 412 407	Filter 412 407	Gasfilter 412 407	Сетчатый фильтр 412 407	13 016 606 13 016 605
478	Manostat GW 150 A5 GW 500 A5	Manostato GW 150 A5 GW 500 A5	Manóstato GW 150 A5 GW 500 A5	Press. contr. device GW 150 A5 GW 500 A5	Druckwächter GW 150 A5 GW 500 A5	Регулятор GW 150 A5 GW 500 A5	13 016 461 13 016 337
480	Bride/MB 2x 407 Rp 3/4 412 Rp 1"1/4	Flangia/MB 2x 407 Rp 3/4 412 Rp 1"1/4	Brida/MB 2x 407 Rp 3/4 412 Rp 1"1/4	Flange/MB 2x 407 Rp 3/4 412 Rp 1"1/4	Flansch/MB 2x 407 Rp 3/4 412 Rp 1"1/4	Фланец/MB 2x 407 Rp 3/4 412 Rp 1"1/4	13 015 585 13 015 586
481	Filtre extérieur Rp 1 Elément filtrant Rp 1	Filtro esterno Rp 1	Filtro exterior	External filter Element. filtr.	ausseres Filter Filtereinsatz	Наружный фильтр Rp 1 Фильтрующий элемент Rp 1	13 016 006 13 015 863



**Schémas électrique et hydraulique**  
**Schemi elettrico e idraulico**  
**Esquema eléctrico y hidráulico**  
**Electric and hydraulic diagrams**  
**Elektro- und Hydraulikschema**  
**Электрические и гидравлические схемы**



**C24, 30 GX 507/8..... 13 014 839**



C 24 GX 507/8T1 p 20	13 005 060
C 24 GX 507/8T2 p 20	13 005 061
C 24 GX 507/8T1 p 300	13 005 062
C 24 GX 507/8T2 p 300	13 005 063
C 30 GX 507/8T1 p 20	13 005 068
C 30 GX 507/8T2 p 20	13 005 069
C 30 GX 507/8T1 p 300	13 005 070
C 30 GX 507/8T2 p 300	13 005 071



Alimentation  
Alimentazione elettrica  
Suministro eléctrico  
Einspeisung  
Power supply  
Elektrische voeding

Chaudière / Caldaia / Caldera / Boiler / Kessel / Ketel

Options / Opzione / Opciones / Options / Optionen / Optie

<b>F1</b>	Th./pr. de sécurité Termostato di sicurezza Limitador de sobrecalentamiento Safety limiter Sicherheitsbegrenzer Beveiliging thermostaat	<b>S6</b>	Limiteur Limitatore Limitador Limiter Begrenzer Beperkingsthermostaat	<b>H6</b>	Panne Inconveniente Fallo Trouble Störung Storing	<b>P4 / P5</b>	Compteur horaire Contaore Contador horario Running hours meter Betriebsstundenzähler Uurteller	<b>S7</b>	2 allures ou PID bistadio o PID 2-etapas o PID 2 stages or PID 2-stufig oder PID 2-trap of PID
-----------	--	-----------	--	-----------	--	----------------	---	-----------	---

230 V~ 50Hz

L N  $\perp$

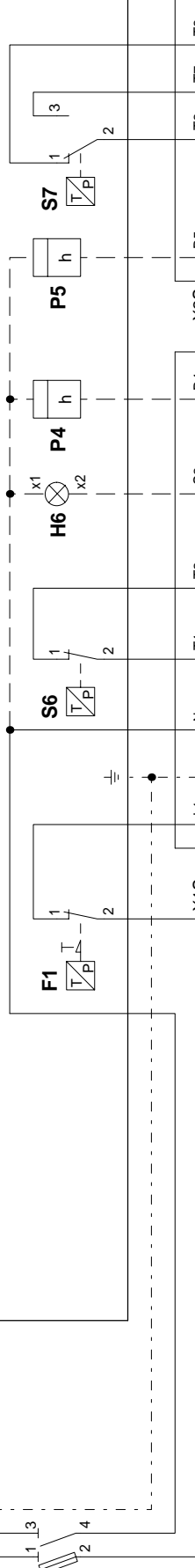
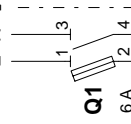

Mise à la terre conformément au réseau local  
Messa a terra in conformità alla rete locale  
Puesta a tierra en conformidad con la red local  
Earthing in accordance with local regulation  
Erdung nach örtlichen Vorschriften  
Aarding in overeenstemming met het plaatselijk net

La protection de l'installation doit être conforme aux normes en vigueur.

La protezione dell'installazione deve essere in conformità alle norme in vigore.  
La protección de la instalación debe ser en conformidad con las normas en vigor.  
Protection of the installation must comply with the actual norms.  
Der Schutz der Anlage muss den geltenden Normen entsprechen.  
Bescherming van de installatie moet in overeenstemming volgens de normen die van kracht zijn.

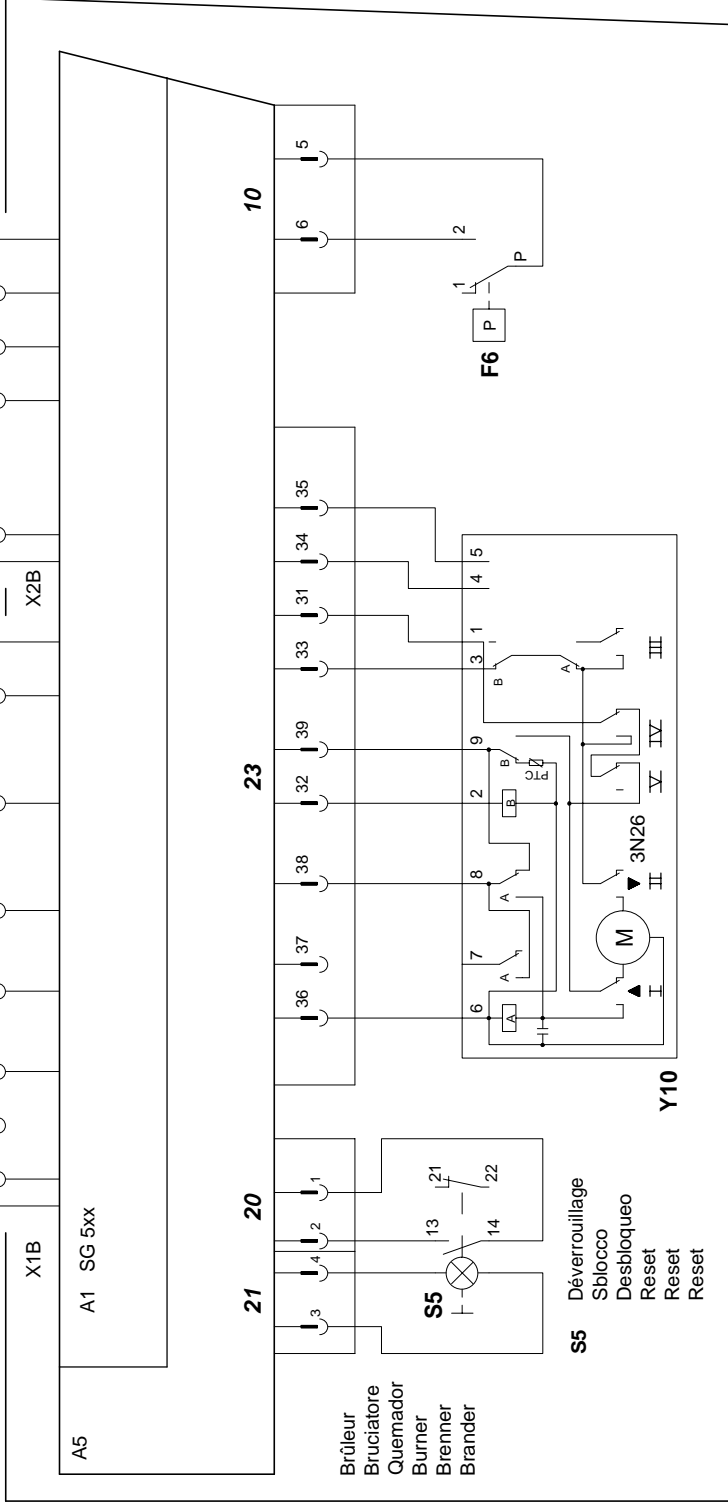



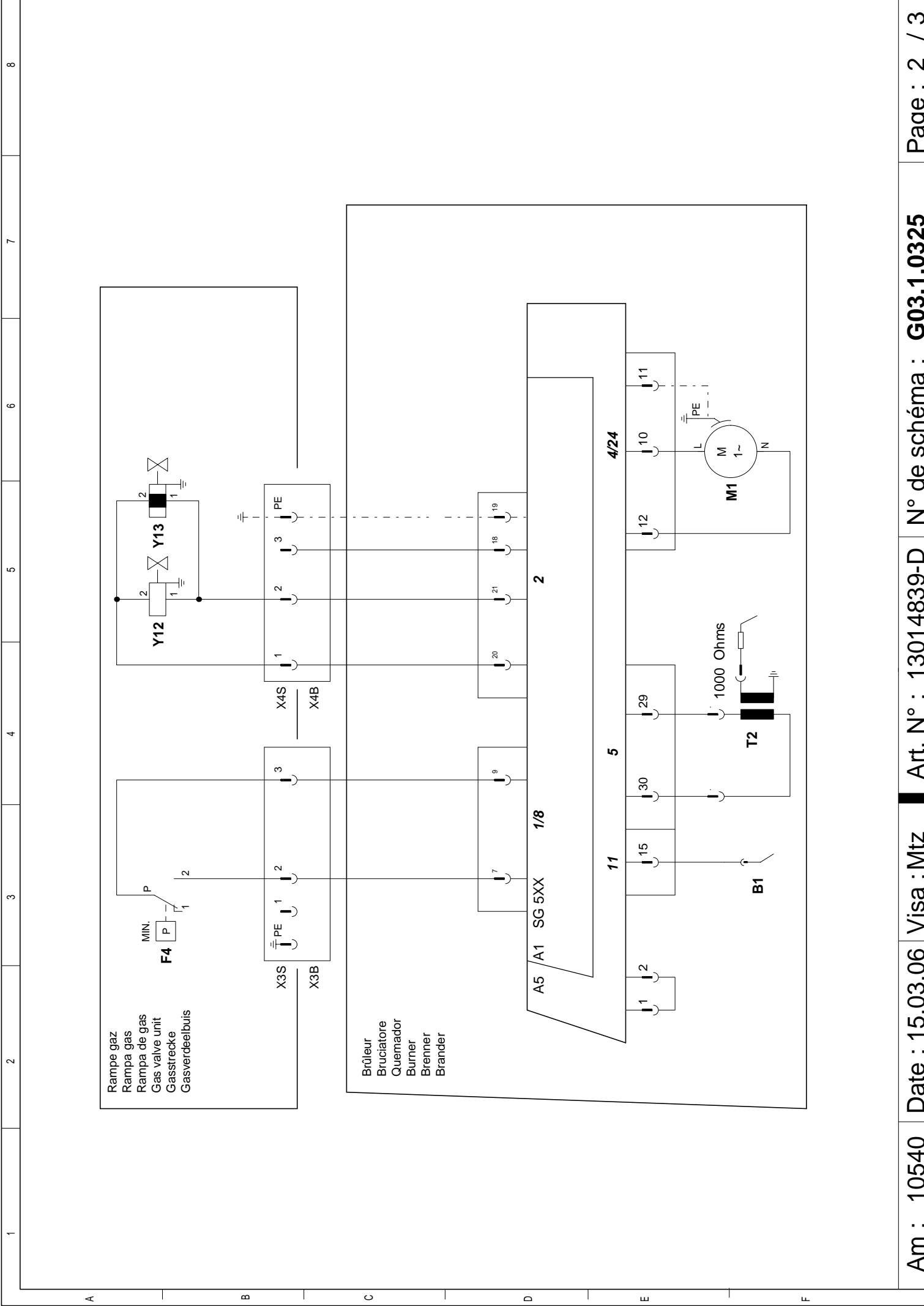

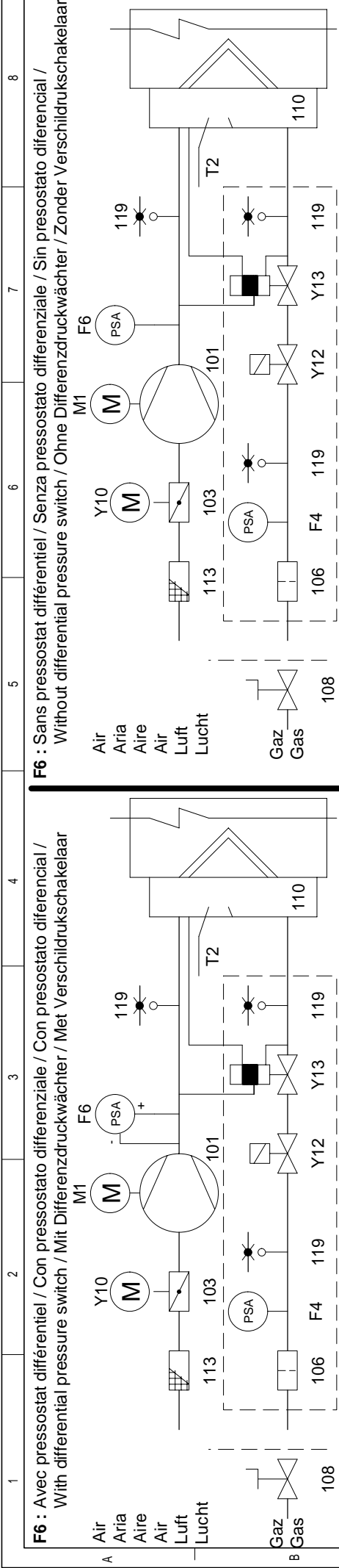

**F6** : Sans pressostat différentiel / Senza pressostato differenziale / Sin pressostato diferencial / Without differential pressure switch / Ohne Differenzdruckwächter / Zonder Verschildrukschakelaar

Air / Aria / Aire / Air / Luft / Lucht / Gaz / Gas

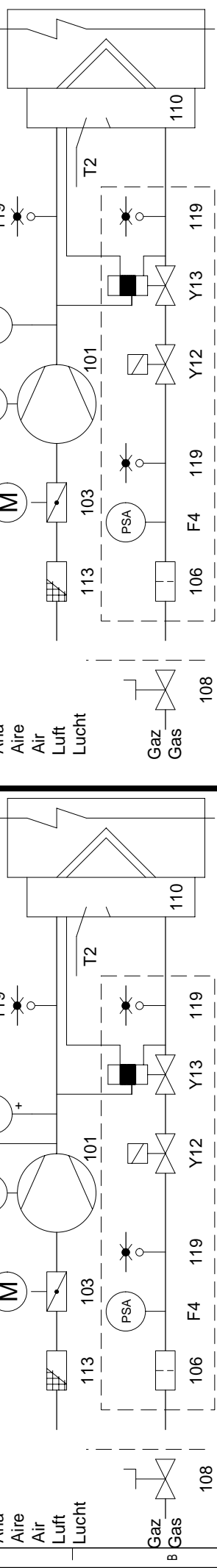

	1	2	3	4	5	6	7	8
A1	Coffret de contrôle	Programmatore di comando	Caja de mando y seguridad	Control and safety unit	Feuerungsautomat	Bedienings en veiligheidskoffer		
A5	Cassette de raccordement	Cassetta di collegamento	Casete de conexión	Connection cartridge	Anschlußkasten	Verbindingsdoos		
B1	Electrode d'ionisation	Elettrodo d'ionizzazione	Electrodo de ionización	Ionisation electrode	Ionisationselektrode	Ionisatie-elektrode		
F4	Manostat gaz	Pressostato gaz	Presostato de gas	Gas pressure switch	Gasdruckwächter	Gaspressostaat		
F6	Manostat air	Pressostato aria	Presostato de aire	Air pressure switch	Luftdruckwächter	Luchtpressostaat		
M1	Moteur du brûleur	Motore del bruciatore	Motor del quemador	Burner motor	Brennmotor	Brandermotor		
T2	Transformateur d'allumage	Trasformatore d'accensione	Transformador de encendido	Ignition transformer	Zündtrafo.	Ontstekings-transformator		
Y10	Servomoteur	Servomoteur	Servomotor	Servomotor	Stellantrieb	Servomotor		
Y12	Vanne gaz de sécurité	Valvola sicurezza gas	Valvula de seguridad de gas	Gas safety valve	Gasventilgasseitig	Veiligheidsafsluiter gas		
Y13	Vanne gaz principale	Valvola principale gas	Valvula de gas principal	Gas valve burner side	Gasventil Brennerseitig	Hoofdafsluiter gas		
101	Ventilateur	Ventilatore	Ventilador	Blower	Ventilator	Ventilator		
103	Volet d'air	Serranda aria	Trampilla de aire	Air flap	Luftklappe	Luchtklep		
104	Régulateur de pression	Regolatore della pressione	Regulador de presión	Pressure regulator	Druckregler	Drukregelaar		
106	Filtre	Filtro	Filtro	Filter	Filter	Filter		
108	Vanne manuelle (Option)	Valvola manuale (Opzione)	Valvula manual (Opcion)	Manual valve (Option)	Handventil (Option)	Handventiel (Optie)		
110	Injecteur gaz	Ugello gas	Injector de gas	Gas injector	Gasinjektor	Gasinjector		
113	Grille d'aspiration	Scatola dell'aria	Caja de aire	Air box protection	Ansauggitter	Luchthuis		
119	Prise pression	Prisa pressione	Toma de presión	Pressure take-off	Messnippel	Meetnippel		





**CUENOD**  
18 rue des Buchillons  
F – 74100 Annemasse